

JACKOBOARD® S-KIT 3

Add a new shape to your bathroom.

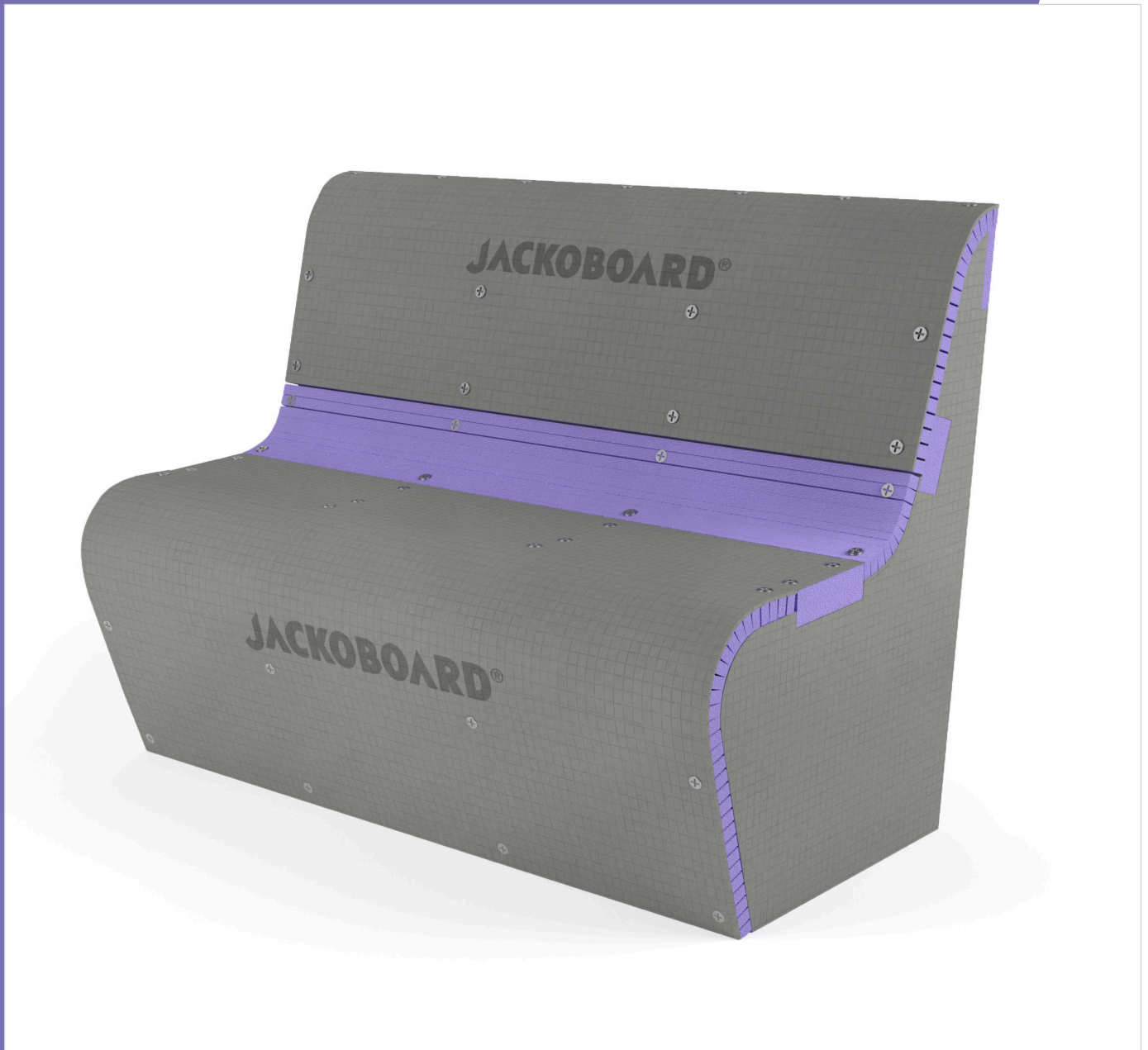

Installation Instructions

JACKON
by BEW/

JACKOBOARD® S-Kit 3 - System components

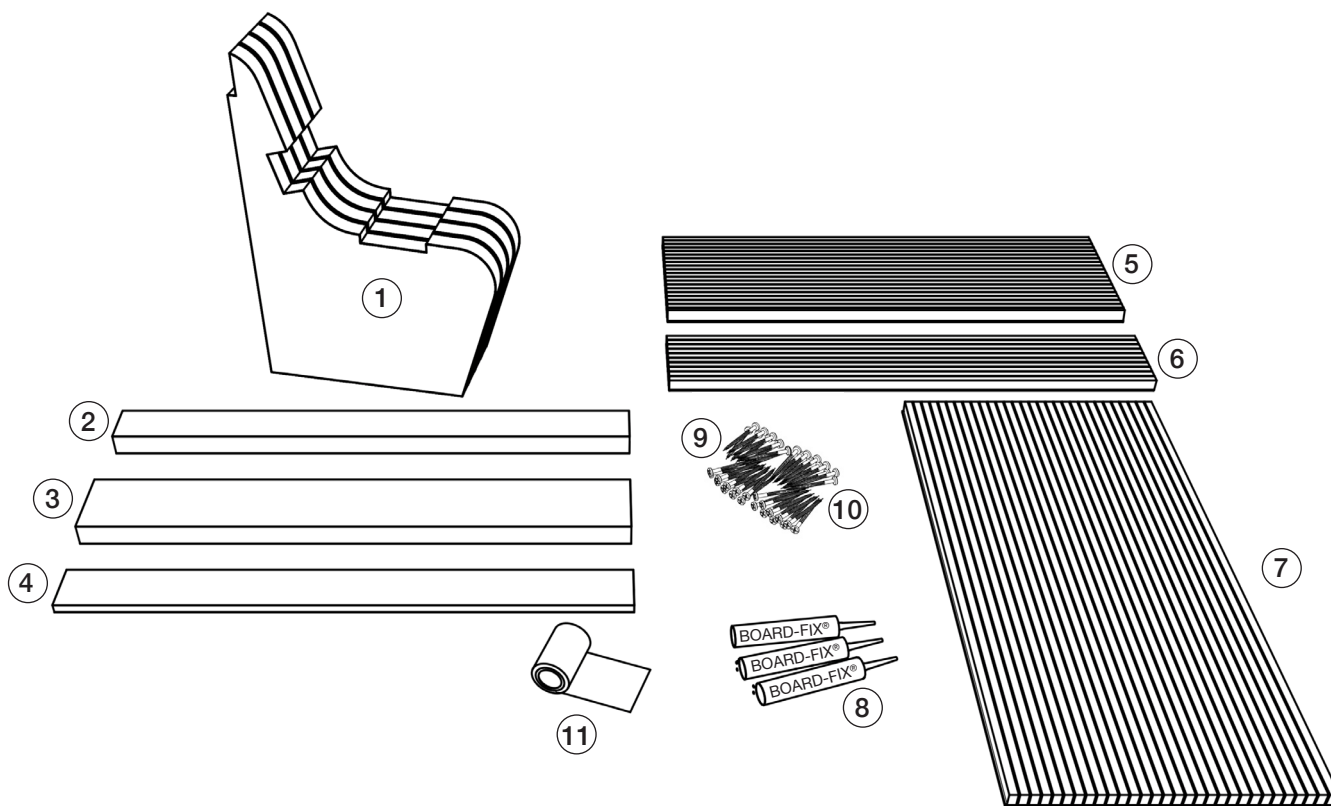

- ① 4 x supporting panels A (2x with coating, 2x without coating)
- ② 1 x strut C2 (1200 x 100 x 50 mm)
- ③ 1 x strut C1 (1200 x 160 x 50 mm)
- ④ 1 x strut C3 (1200 x 108 x 20 mm)
- ⑤ 1 x cover B3 (1200 x 392 x 30 mm)
- ⑥ 1 x cover B2 (1200 x 200 x 30 mm)
- ⑦ 1 x cover B1 (1200 x 600 x 30 mm)
- ⑧ 3 x BOARD-FIX® adhesive and sealing agent
- ⑨ 47 x stainless steel screws 6.0 x 120 mm
- ⑩ 8 x stainless steel screws 5.0 x 50 mm
- ⑪ 1 x JACKOBOARD® glass fibre tape

You will also need: pencil, folding rule, cordless screwdriver, scissors, flexible tile adhesive, finishing trowel, cartridge gun, water scale

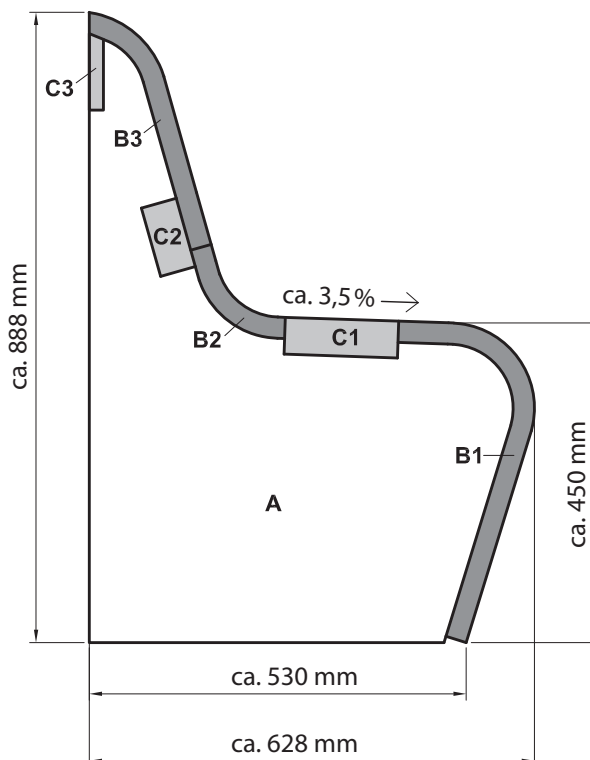

Field of application:

The bench can generally be used inside heated buildings, particularly in areas with a higher level of humidity, such as bathrooms, spa areas and steam baths.

The application temperature limit for the bench is 75°C. Areas in which this temperature is exceeded, e.g. in saunas, must be avoided.

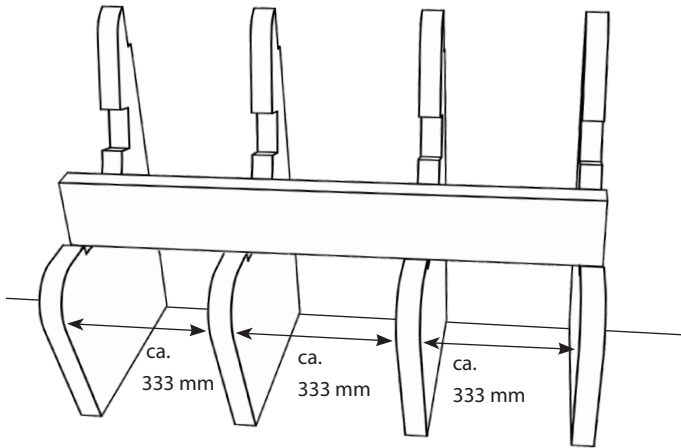
Application:

- 1) Set up supporting panels A an equal distance apart.
Please note: The 2 supporting panels without coating are arranged in the centre.

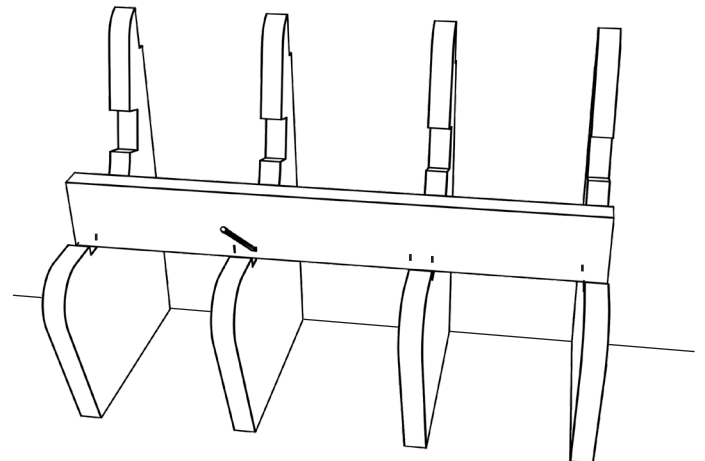

- 2) Mark the positions of the supporting panels A on strut C1.

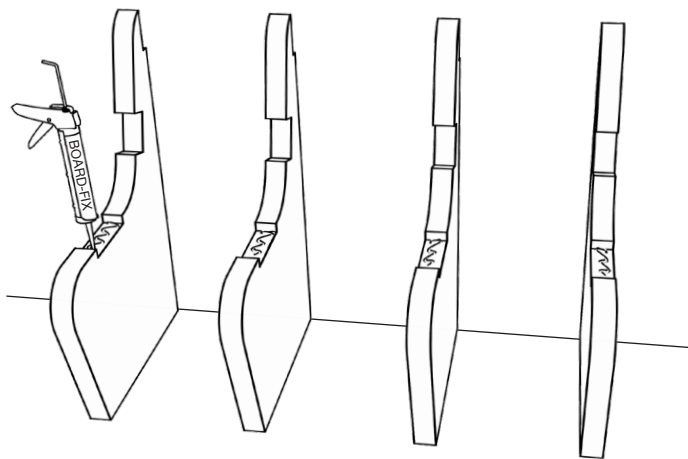

- 3) Apply BOARD-FIX® to the recessed area for strut C1.

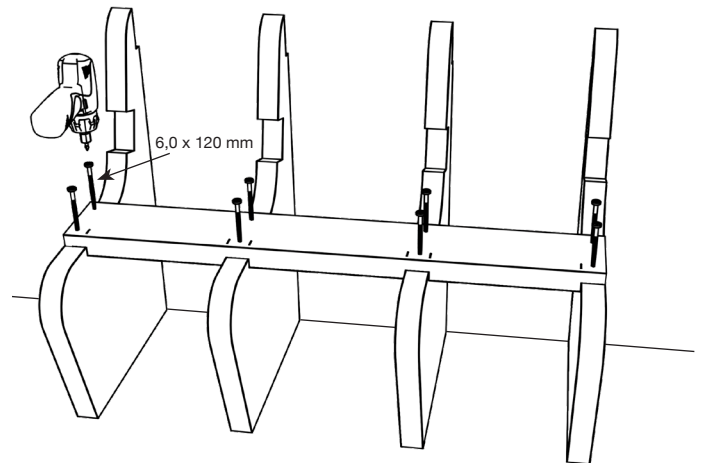

- 4) Glue on strut C1. Align supporting panels A with the marks and bolt on.

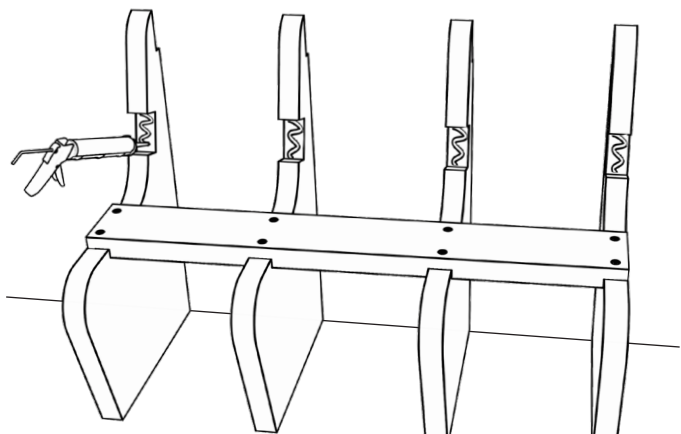

5) Apply BOARD-FIX® to the recessed area for strut C2.

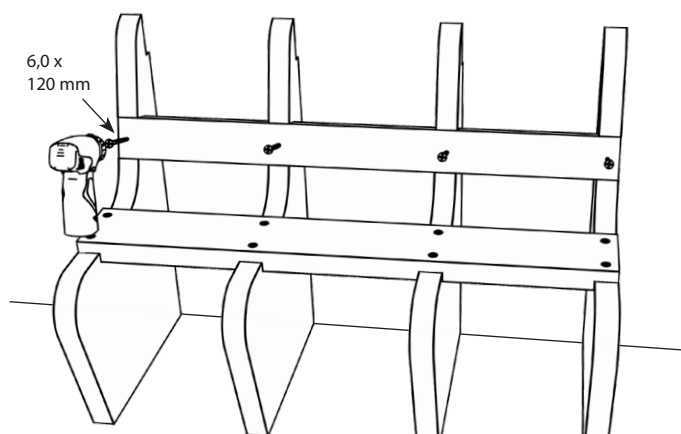

6) Glue on strut C2. Align supporting panels A the same distances apart and bolt on.

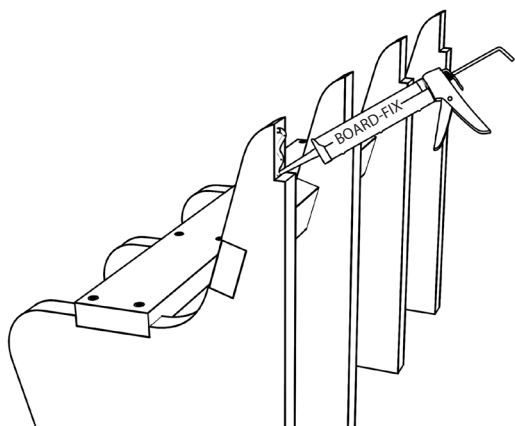

7) Apply BOARD-FIX® to the recessed area for strut C3.

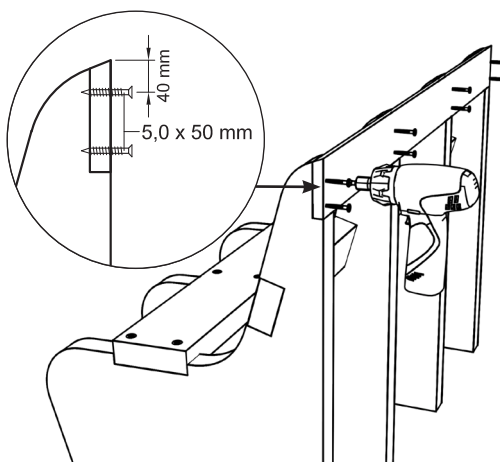

8) Glue on strut C3 and bolt in place.

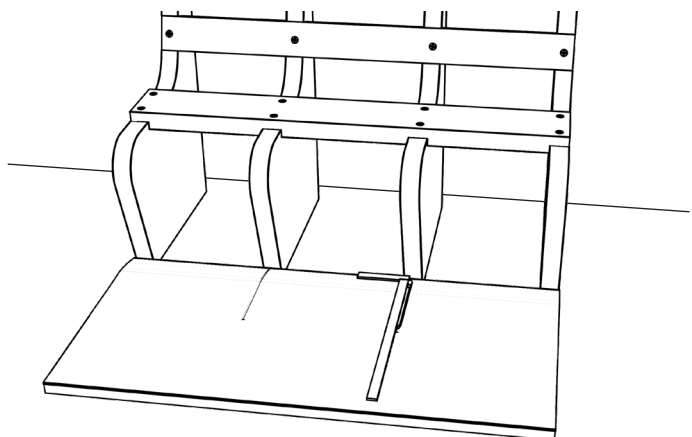

9) Fit cover B1 and mark the positions for the middle supporting panels.

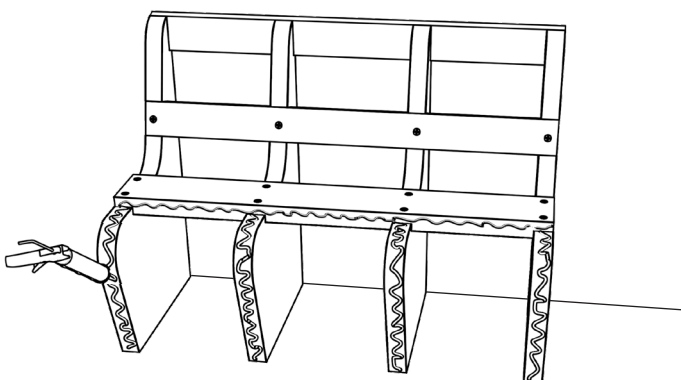

10) Apply BOARD-FIX® to supporting panels A and to the long side of strut C1.

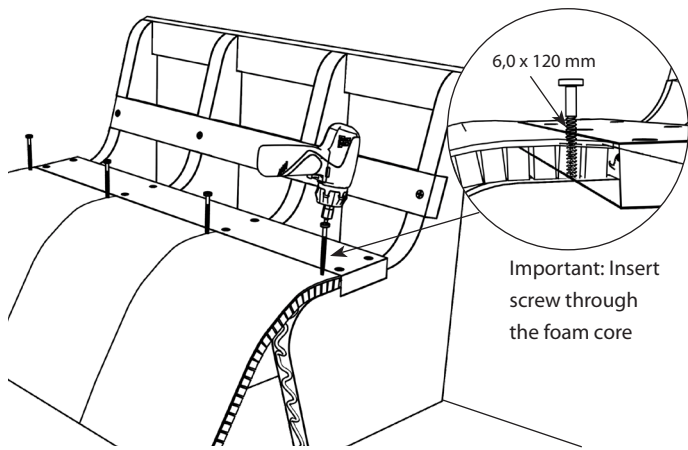

11) Glue on cover B1 and bolt on at the top.

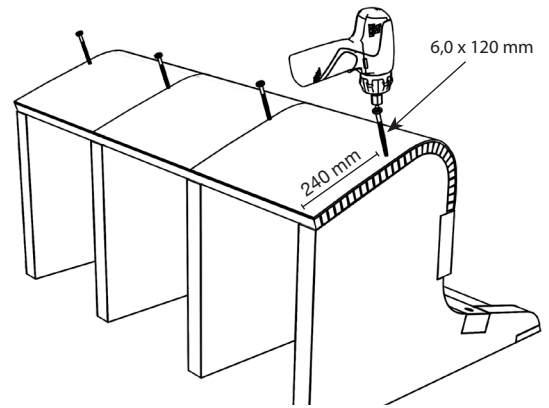

12) Place the bench on its back. Guide cover B1 firmly around the curve, press on and bolt in place.

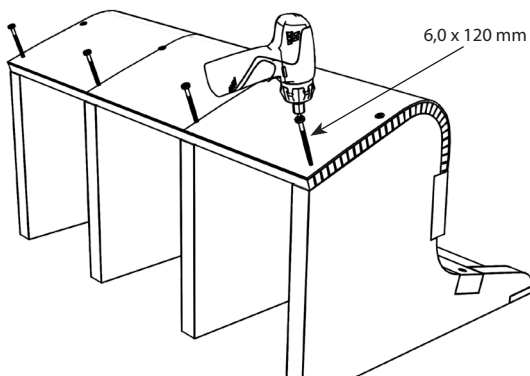

13) Bolt on the lower row.

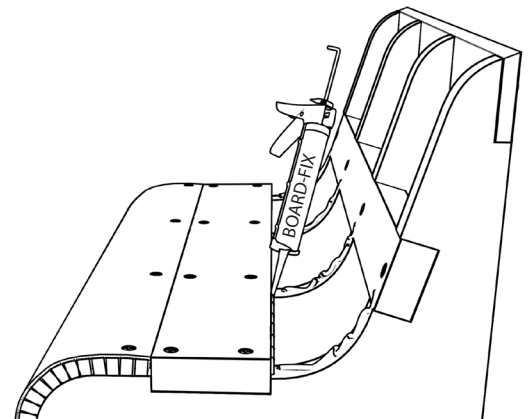

14) Apply BOARD-FIX® to supporting panels A and to the long side of strut C1.

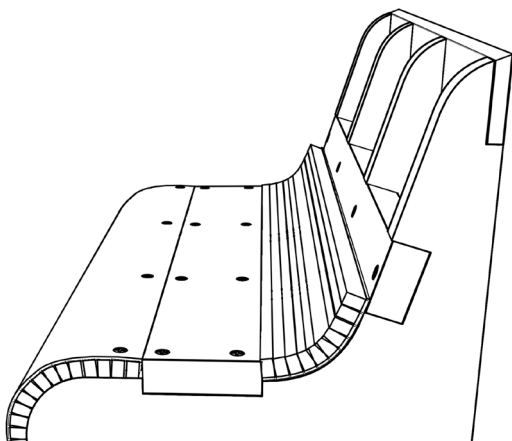

15) Prebend cover B2 before gluing on to relieve the tension. Then glue on cover B2 with the slotted side facing upwards.

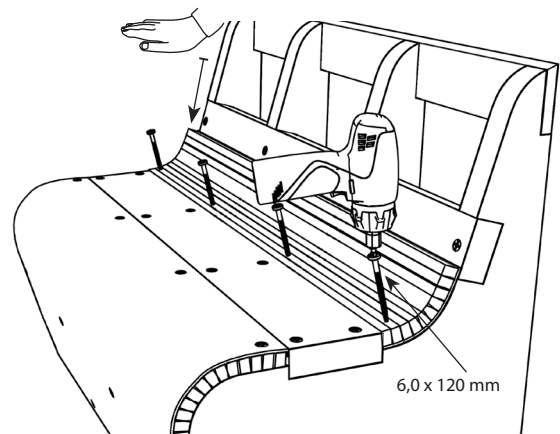

16) Press on cover B2 from above and bolt in place. First bolt on the lower row....

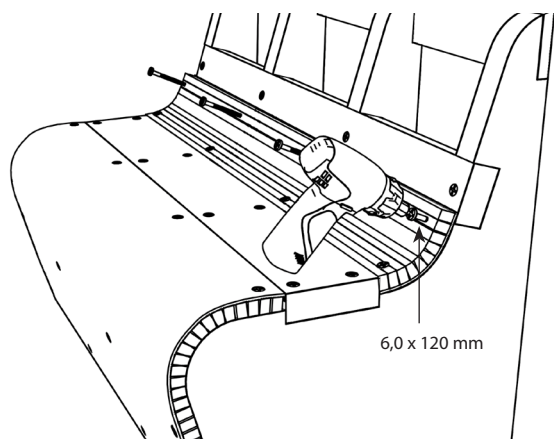

17)then the upper row.

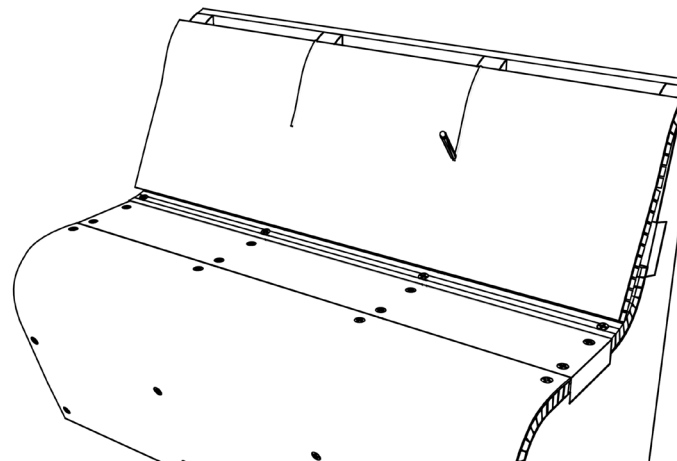

18) Fit cover B3 and mark the positions for the middle supporting panels.

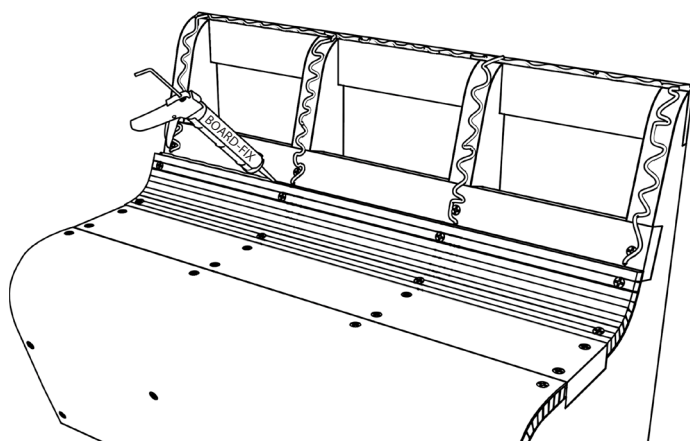

19) Apply BOARD-FIX® to supporting panels A, strut C1 and cover B2.

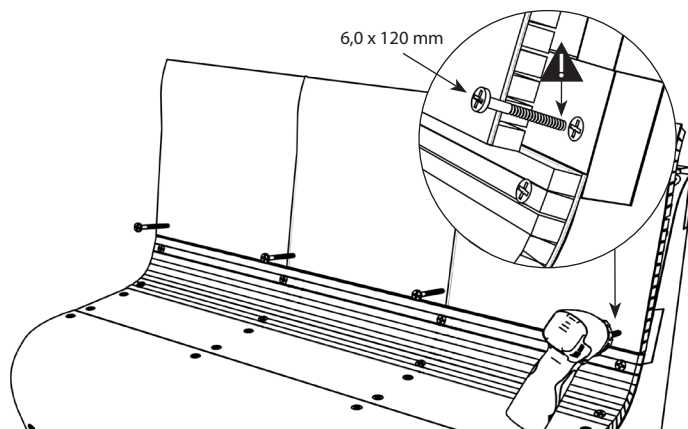

20) Glue on cover B3 and bolt on from below.

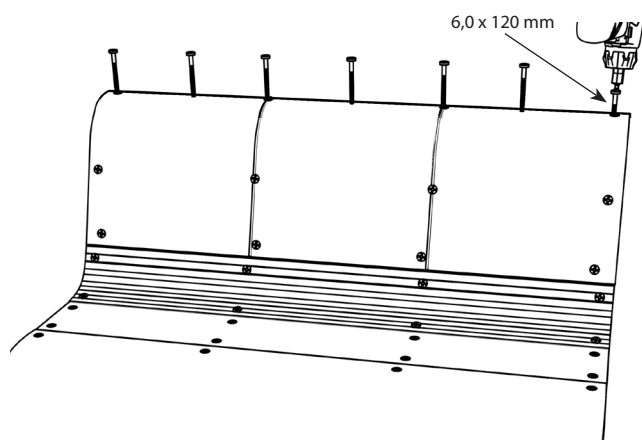

21) Glue on cover B3 and bolt on from below.

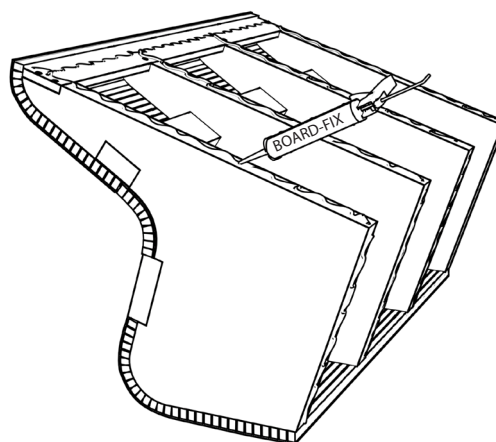

22) The bench must be glued to the wall and the floor. To do this, apply BOARD-FIX® to the front surfaces of the back and underside.

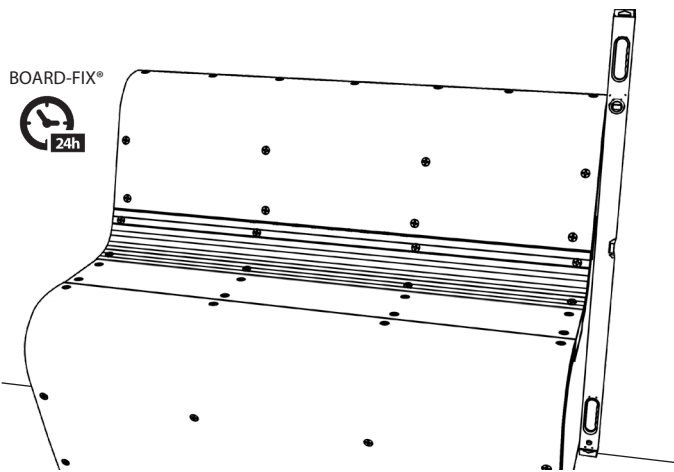

23) Glue the bench to the wall and the floor so that it is positioned upright.

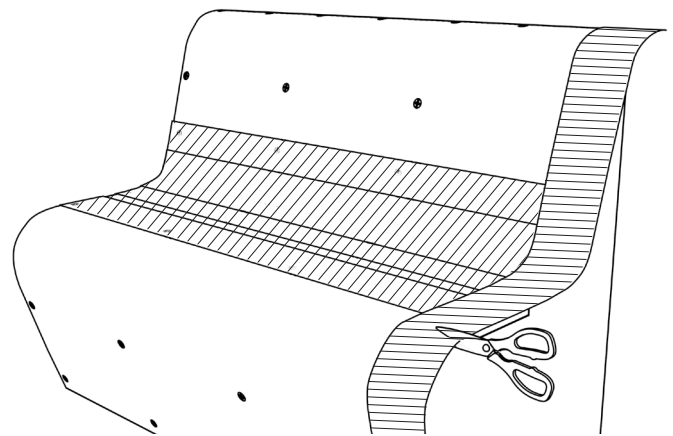

24) Tape over cover B2, all butt joints and visible edges with JACKOBOARD® self-adhesive glass fibre tape.

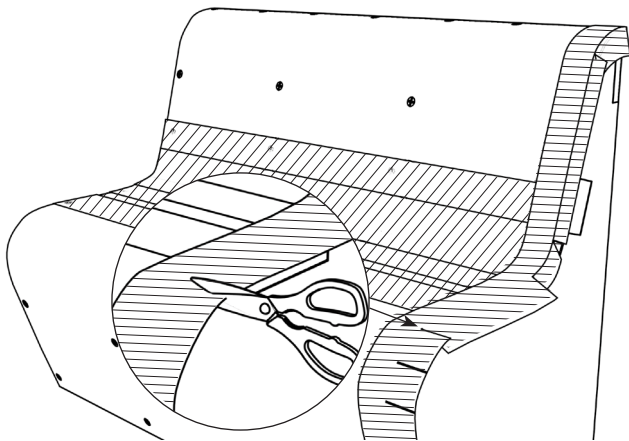

25) Cut into the glass fibre tape with scissors at the curves and glue on so that they overlap.

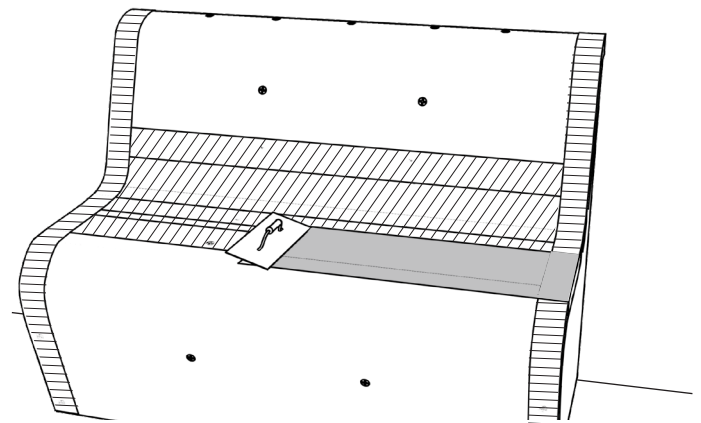

26) Apply tile adhesive over the glass fibre tape.

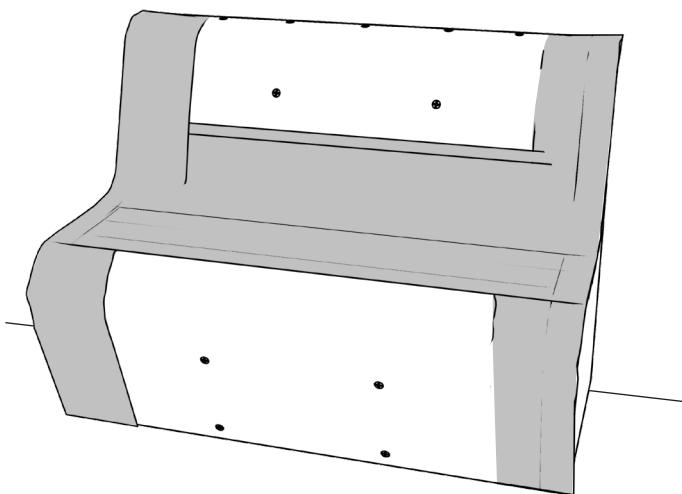

27) The bench is now finished and can be tiled.

General information:

Tiling/plastering:

The seat and backrest must be tiled to ensure an adequate load distribution. In the area of the curves, mosaic tiles up to max. 25 x 25 mm or linear mosaic tiles with a maximum width of 25 mm should be used. The other surfaces can be tiled, spackled or plastered. A suitable primer (suitable for cementitious substrates) must be applied before using gypsum-based plasters or filling compounds. Particularly for use in a steam bath, the tiles must be glued with an epoxy resin tile adhesive.

Wet areas:

In wet areas (e.g. in a shower), the complete bench must be sealed with an approved liquid composite sealant. In this case the bench must be completely tiled.

Electric heating mat:

The use of an electric heating mat on the bench is essentially possible in non-wet areas. The heating mat should not be thicker than 2 mm and must not exceed a temperature of 75°C. Glue the heating mat to the whole surface bench with a flexible tile adhesive using a notched trowel before tiling. There must be voids or cavities. A fully load-bearing substrate must be available for the subsequent tiling. The instructions of the heating system manufacturer must be observed.

Please note

The information provided in this leaflet is based on our knowledge and experience to date. It does not constitute a guarantee in any legal sense. When using this product, please always bear in mind the circumstances of the particular intended application, especially with regard to physical, technical and legal construction issues.

JACKON Insulation GmbH

Carl-Benz-Straße 8
D-33803 Steinhagen

T +49 (0) 5204 9955 - 0
F +49 (0) 5204 9955 - 400

E info@jackodur.com
W www.jackon-insulation.com

JACKON
by BEW