

JACKOBOARD® S-KIT 1

Add a new shape to your bathroom.

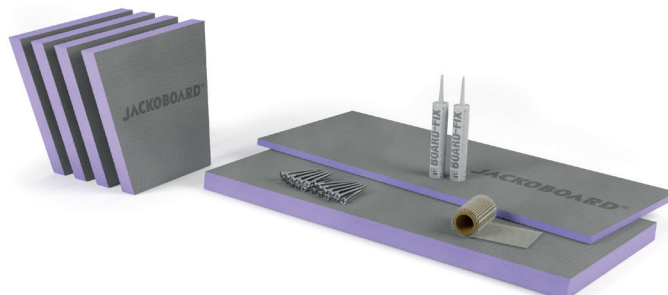

Installation Instructions

JACKON
by BEW

JACKOBOARD® S-Kit 1 – System components

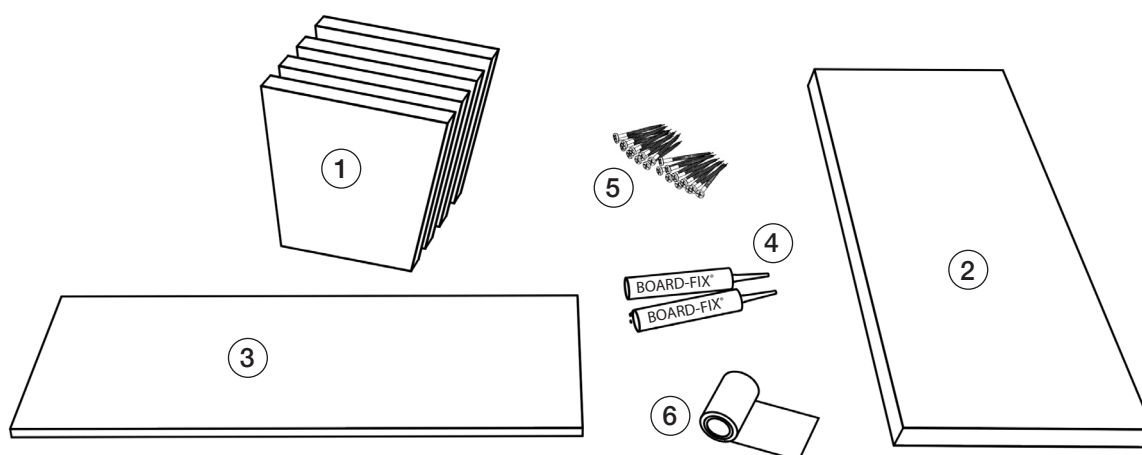

- ① 4 x supporting panels A, 50 mm (2x with coating, 2x without coating)
- ② 1 x cover B1 (1200 x 483 x 50 mm)
- ③ 1 x cover B2 (1200 x 449 x 20 mm)
- ④ 2 x BOARD-FIX® adhesive and sealing agent
- ⑤ 20 x stainless steel screws 6.0 x 120 mm
- ⑥ 1 x JACKOBOARD® glass fibre tape

You will also need: pencil, folding rule, cordless screwdriver, scissors, flexible tile adhesive, finishing trowel, cartridge gun, water scale

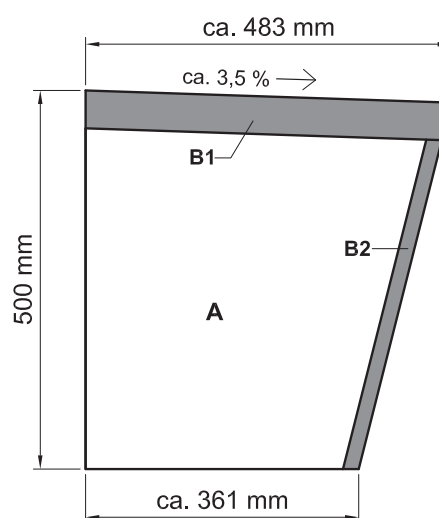

General information:

Field of application:

The bench can generally be used inside heated buildings, particularly in areas with a higher level of humidity, such as bathrooms, spa areas and steam baths. The application temperature limit for the bench is 75°C. Areas in which this temperature is exceeded, e.g. in saunas, must be avoided.

Tiling/plastering:

The seat and backrest must be tiled to ensure an adequate load distribution. In the area of the curves, mosaic tiles up to max. 25 x 25 mm or linear mosaic tiles with a maximum width of 25 mm should be used. The other surfaces can be tiled, spackled or plastered. A suitable primer (suitable for cementitious substrates) must be applied before using gypsum-based plasters or filling compounds. Particularly for use in a steam bath, the tiles must be glued with an epoxy resin tile adhesive.

Wet areas:

In wet areas (e.g. in a shower), the complete bench must be sealed with an approved liquid composite sealant. In this case the bench must be completely tiled.

Electric heating mat:

The use of an electric heating mat on the bench is essentially possible in non-wet areas. The heating mat should not be thicker than 2 mm and must not exceed a temperature of 75°C. Glue the heating mat to the whole surface bench with a flexible tile adhesive using a notched trowel before tiling. There must be voids or cavities. A fully load-bearing substrate must be available for the subsequent tiling. The instructions of the heating system manufacturer must be observed.

Application:

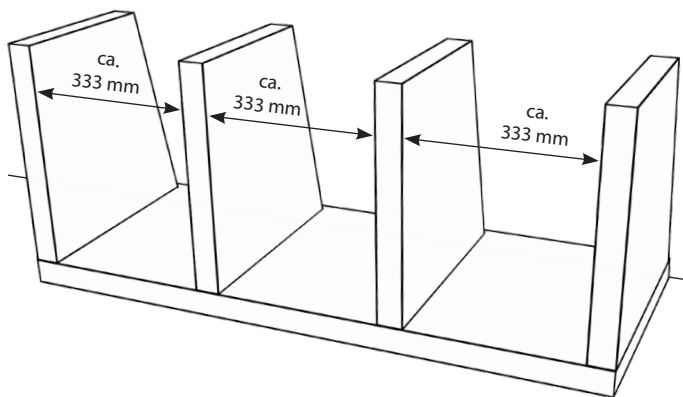

1) Set up supporting panels A the same distance apart on the underside of cover B1...

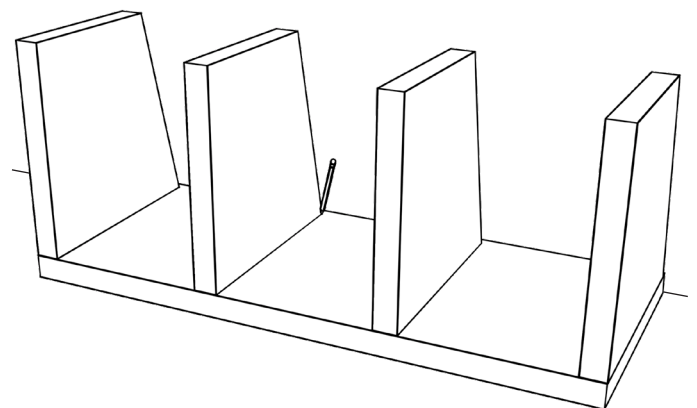

2) ...and mark the positions.
Please note: The 2 supporting panels without coating are arranged in the centre.

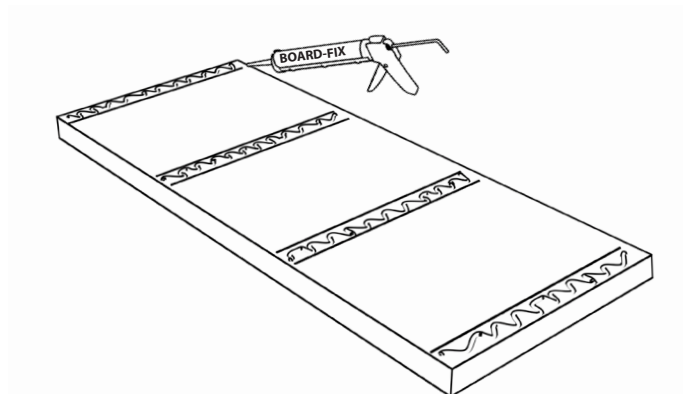

3) Apply BOARD-FIX® along the marked contours.

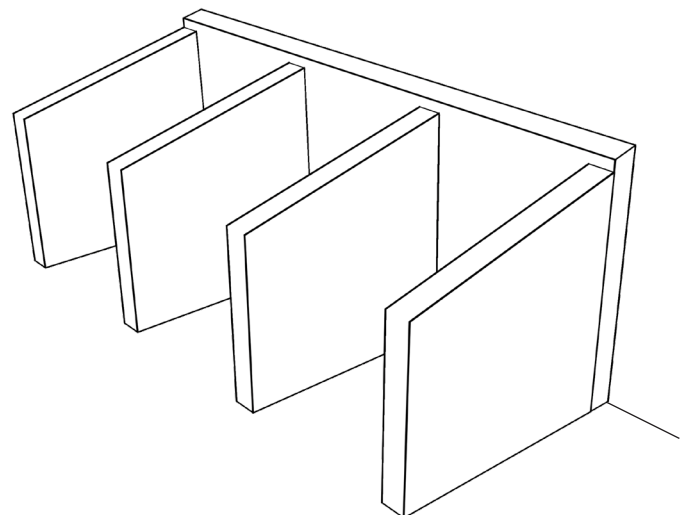

4) Position cover B1 upright. Glue on supporting panels A.

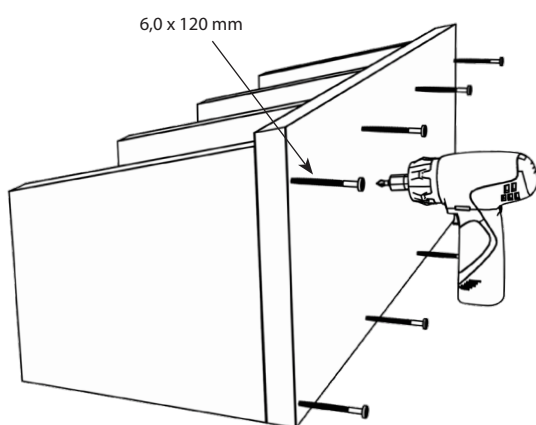

5) Bolt on supporting panels A.

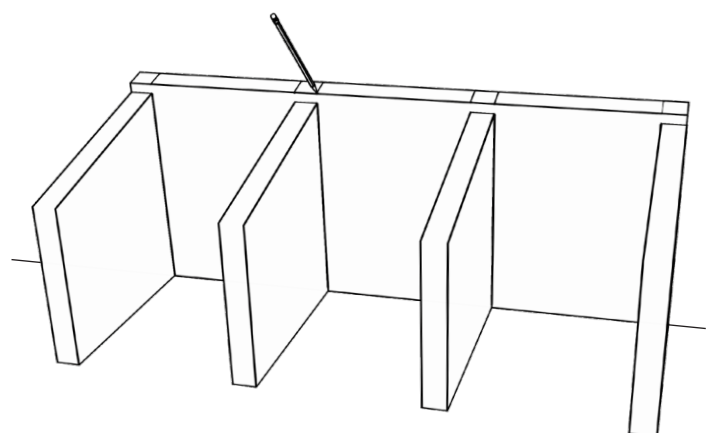

6) Mark the positions of supporting panels A on cover B1.

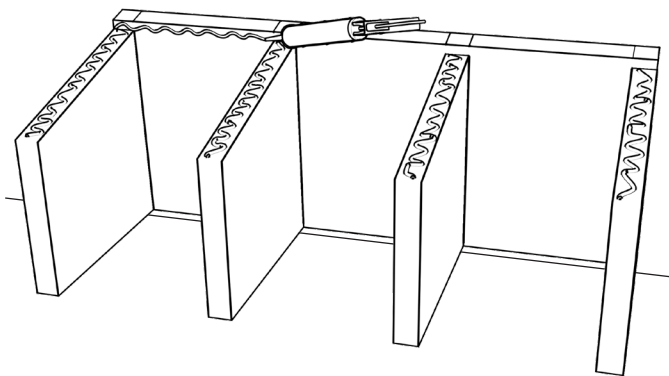

7) Apply BOARD-FIX® to supporting panels A and to the underside of cover B1.

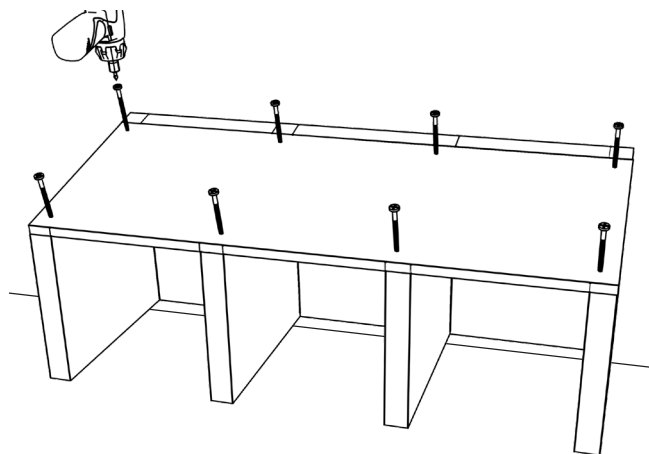

8) Glue on cover B2 and bolt in place.

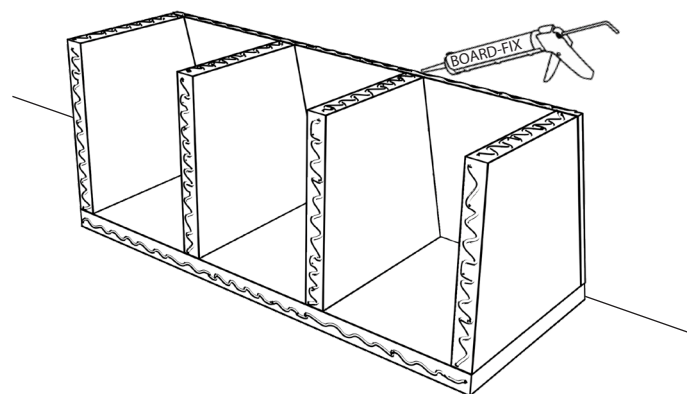

9) The bench must be glued to the wall and the floor. To do this, apply BOARD-FIX® to the front surfaces of the back and underside.

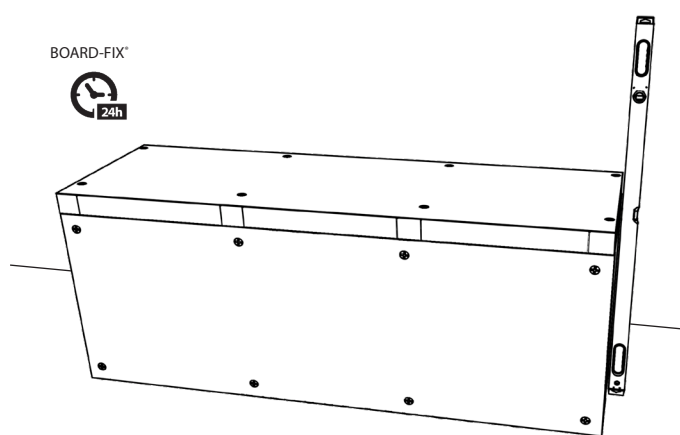

10) Glue the bench to the wall and the floor so that it is positioned upright

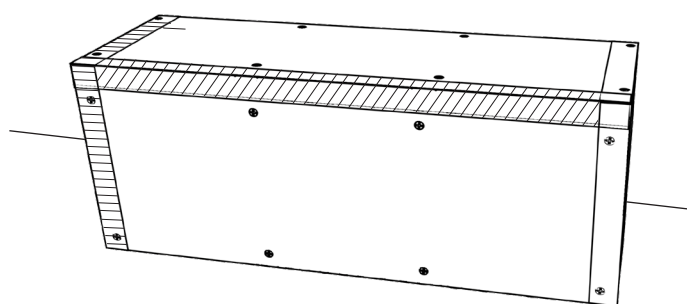

11) Tape over all butt joints and visible edges with JACKOBOARD® self-adhesive glass fibre tape.

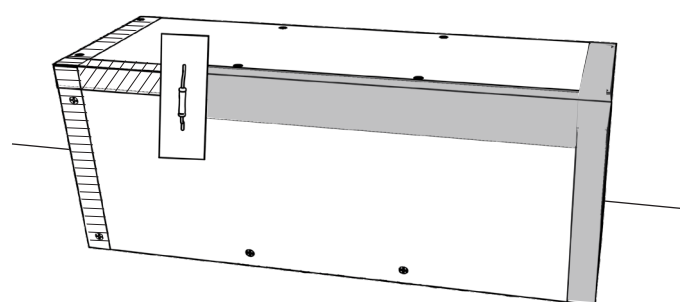

12) Apply tile adhesive over the glass fibre tape. The bench is now finished and can be tiled.

Please note

The information provided in this leaflet is based on our knowledge and experience to date. It does not constitute a guarantee in any legal sense. When using this product, please always bear in mind the circumstances of the particular intended application, especially with regard to physical, technical and legal construction issues.