

JACKOBOARD® Modula R 300

Shelf unit.

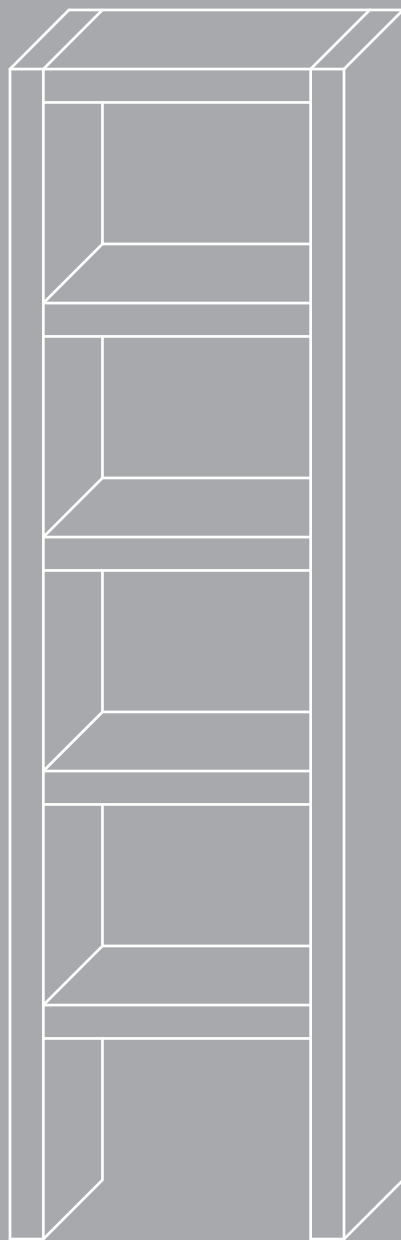

Components

- 5 x shelves (A)
- 2 x side walls (B)

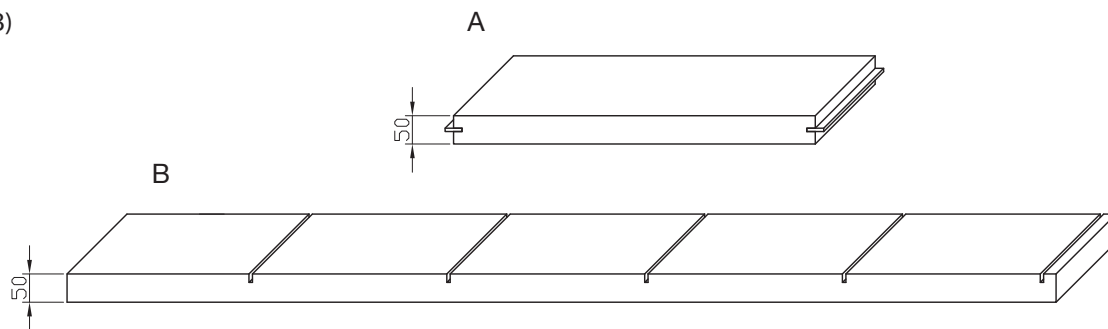

Accessories

- 1 x former board
- 20 x stainless steel screws
- 20 x stainless steel discs
- 2 x adhesive

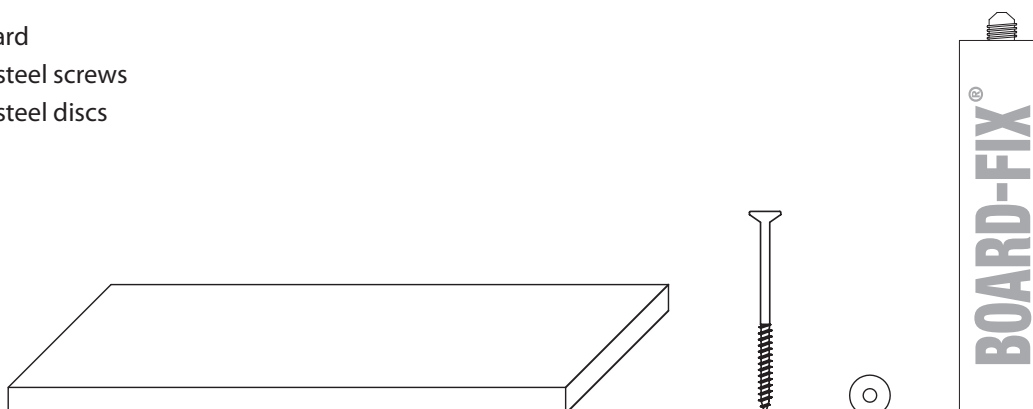

Tools

- Screwdriver
- Cartridge gun

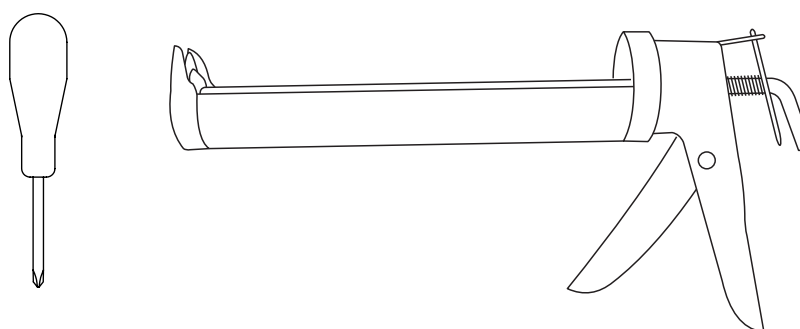

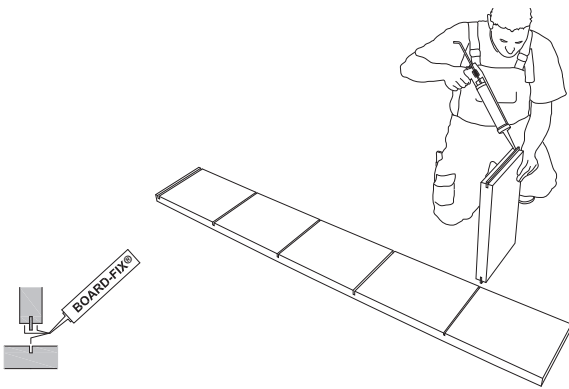

1) Apply adhesive to both joining parts (side wall and shelf).

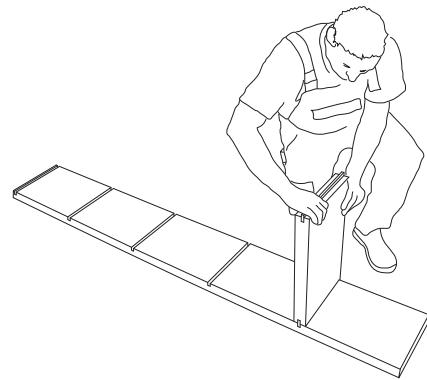

2) Insert the shelf into the groove on the side wall. Make sure the shelf and side wall are flush.

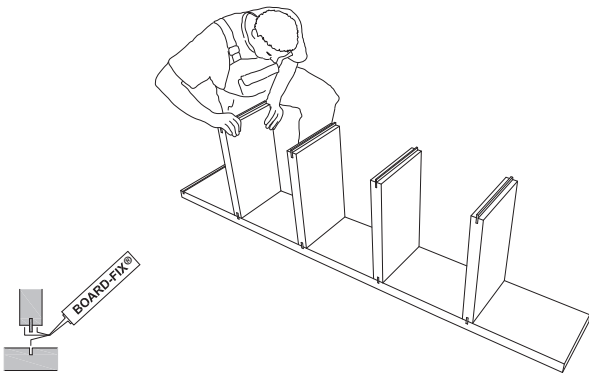

3) The shelves are glued on one after the other.

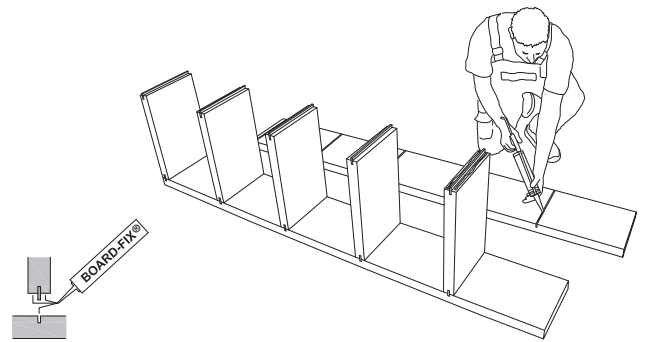

4) Apply adhesive to both joining parts (side wall and shelves).

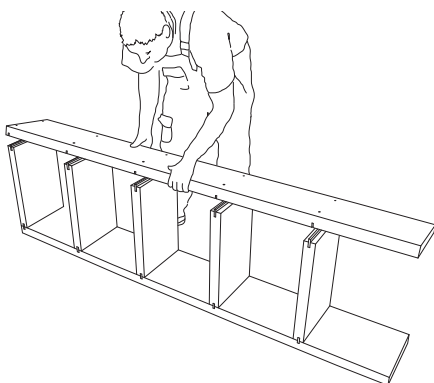

5) Position the second side wall so that each tongue fits into the grooves. Make sure the side wall and shelves are flush.

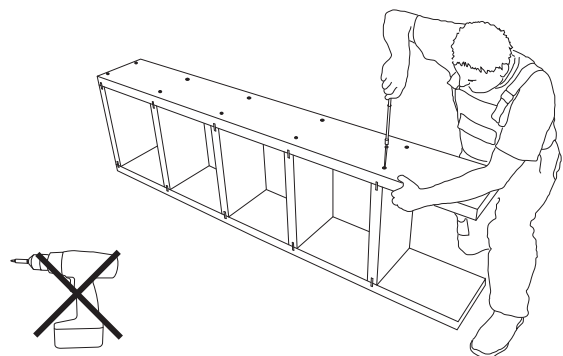

6) Screw both side walls of the unit tight by positioning the enclosed screws and washers in the pre-drilled holes. Using a manual screwdriver, tighten the screws until the heads are flush with the surface.

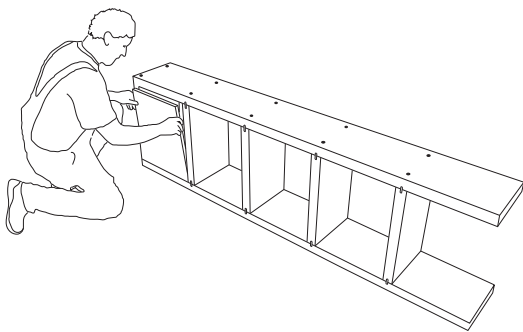

7) Press the former board into the upper compartment of the shelf unit. This serves to keep the shelf unit at right angles and is removed once the adhesive has hardened.

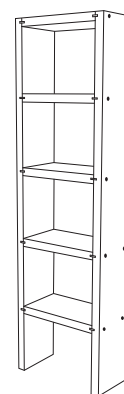

8) The shelf unit is now complete. Once the adhesive has cured (approx. 24 hours) it can be directly covered with tiles or plaster. To ensure permanency, the shelf unit must be bonded to the base (wall and floor) using BOARD-FIX® adhesive.

Notes

BOARD-FIX® adhesive guarantees the permanent bonding of the shelf unit components and is therefore a crucial element of the assembly. The purpose of the screws is to facilitate assembly.

BOARD-FIX® adhesive is usable for about 10 minutes after application. We therefore recommend that you adhere to the sequence in these instructions when assembling the washstand.

Please note

The information in this leaflet is based on our experience and current materials specification. It represents no specific guarantee and the instructions for use outlined should be always observed together with considerations regarding building structure and existing Building Law.