

JACKOBOARD® Aqua Reno Line

Duschen – Systeme auf Rohfußboden, Ablauftechnik integriert
Showers – Systems on unfinished floors, integrated drainage technology
Systèmes pour plancher brut, technique d'écoulement intégrée
Systemen op ruwe vloer, afvoertechniek geïntegreerd

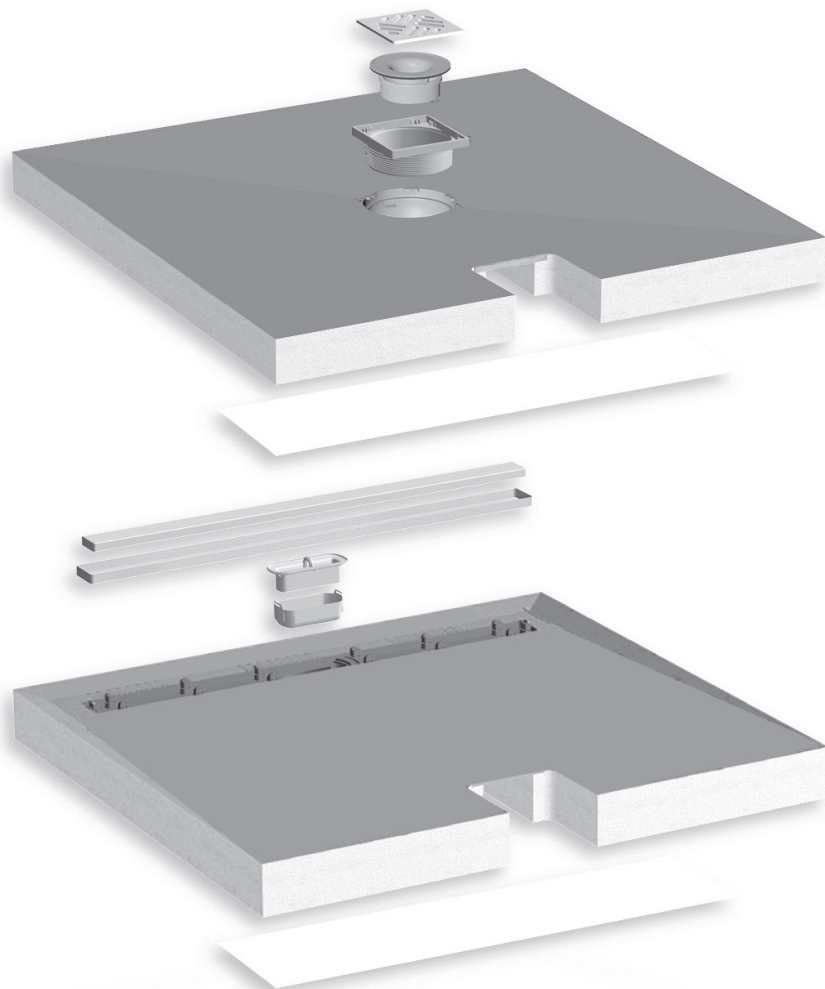

Verarbeitungshinweise / Installation Instructions
Conseils de mise en oeuvre / Verwerkingsinstructies



JACKON
by BEW/

Wichtige Hinweise / Important information Remarques importantes / Belangrijke aanwijzingen

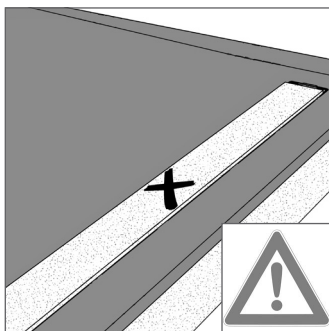
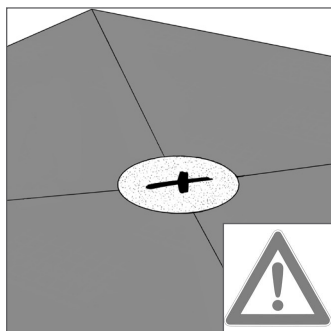

[DE] – 'X' = Bautenschutz

Bitte beachten: Der Duschboden ist nach der Montage bis zur Verfliesung vor Verschmutzung und Beschädigung zu schützen.

[EN] – 'X' = Protective cover

Note: Following installation, the shower base must be protected against dirt and damage until it is tiled.

[FR] – 'X' = Le couvercle de protection

Remarque : Après le montage et jusqu'à la pose du carrelage, le receveur de douche doit être protégé contre les salissures et les dommages.

[NL] – 'X' = Gootbe scherming

Let op: De douchebodem moet na de installatie tot het moment van betegelen worden beschermd tegen vuil en beschadiging.

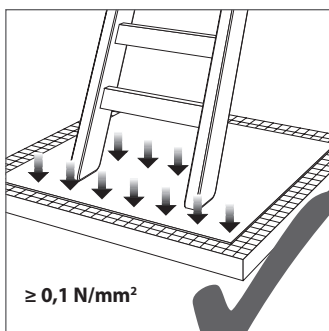
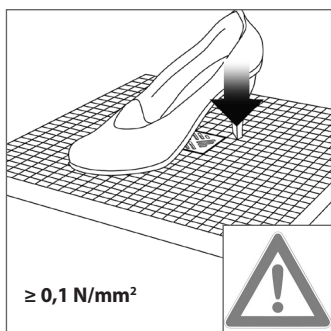

[DE] – HINWEIS: Technische Regeln der Sanitärinstallation werden in dieser Anleitung nicht behandelt.

[EN] – NOTE: Technical rules for sanitary installation are not considered in these instructions.

[FR] – REMARQUE : Les règles techniques de l'installation sanitaire ne sont pas traitées dans ces instructions.

[NL] – LET OP: Technische regels van de sanitaire installatie worden in deze handleiding niet behandeld.

Belagsstärke Duschboden (Fliesen + Kleber) mindestens: 5 mm / max. 17 mm

Upper layer thickness shower base (tile + adhesive) at least: 5 mm / max. 17 mm

Épaisseur de la couche supérieure receveur de douche (carreau + colle) au moins: 5 mm / max. 17 mm

Dikte van de bekleding douchebodem (tegel + lijm) minstens: 5 mm / max. 17 mm



[DE] – Bitte beachten Sie ... unsere Datenblätter, die weitere technische Informationen zur Montage und Verlegung von Belagsmaterialien enthalten. Sie können diese von unserer Homepage www.jackon-insulation.com herunterladen. Generell empfehlen wir bei einer Verlegung von Mosaik von < 5 x 5 cm eine Verklebung und Verfugung mit Reaktionsharz.

[EN] – Please observe ... our data sheets. These contain further technical information regarding the installation and laying of covering materials. You may download them from our homepage www.jackon-insulation.com. We generally advise for tiles < 5 x 5 cm to use epoxy for gluing and grouting.

[FR] – Veuillez tenir compte ... de nos fiches techniques qui contiennent de plus amples informations techniques sur le montage et la pose des matériaux de revêtement. Vous pouvez les télécharger sur notre site internet www.jackon-insulation.com. Pour la mise en oeuvre de mosaïque d'un format < 5 x 5 cm nous conseillons un collage et un jointoyement à lépoxy.

[NL] – Let op ... onze gegevensbladen te letten. Deze bevatten verdere technische informatie m.b.t. plaatsing van afdekmaterialen. U kan deze van onze internetpagina www.jackon-insulation.com downloaden. Algemeen adviseren wij bij het kleven en het voegen van mosaik < 5 x 5 cm een epoxylijm te gebruiken.

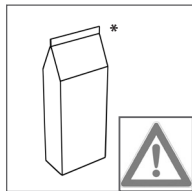
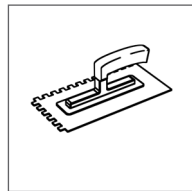
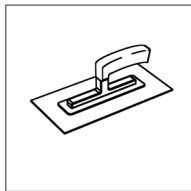
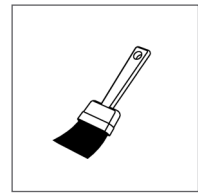
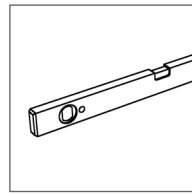
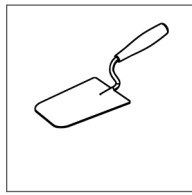
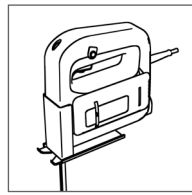
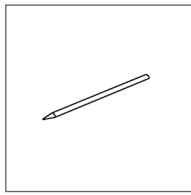

HINWEIS · PLEASE NOTE · REMARQUE · LET OP:

* [DE] – Fliesenkleber C2 [EN] – Tile adhesive C2

[FR] – Colle à carrelage C2 [NL] – Tegellijm C2

[DE] – Schutzhandschuhe/-kleidung, Augen- u. Gesichtsschutz tragen

[EN] – Wear protective gloves/clothing, eye and face protection

[FR] – Porter des gants/vêtements de protection, équipement de protection des yeux/du visage

[NL] – Beschermende handschoenen/kleding, oog- en gelaatsbescherming dragen in deze handleiding niet behandeld.

Verarbeitung / Application / Mise en oeuvre / Vewerking



[www.youtube.com/
@Jackon1000](https://www.youtube.com/@Jackon1000)

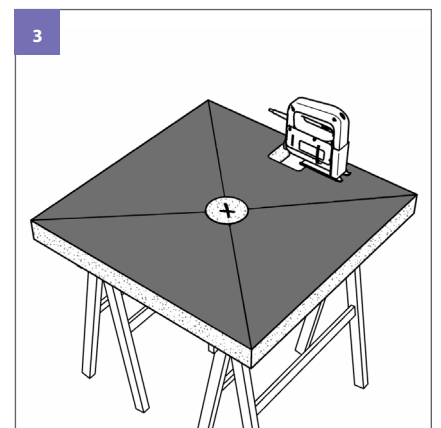
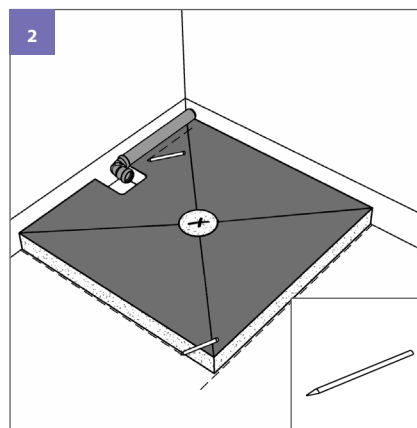
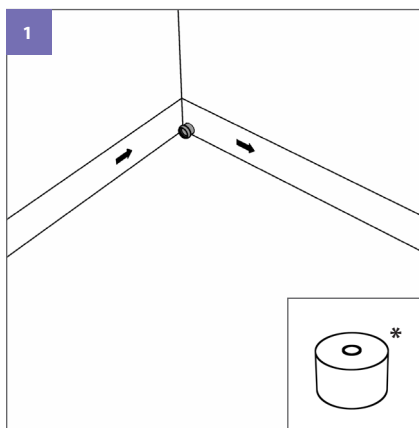

* [DE] – Randdämmstreifen
[EN] – Edge insulation strip
[FR] – Bandes périphériques
[NL] – Randisolatiestrook

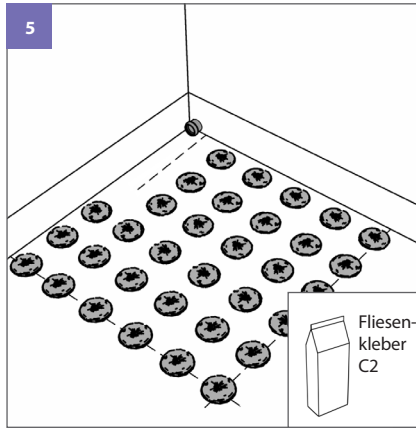
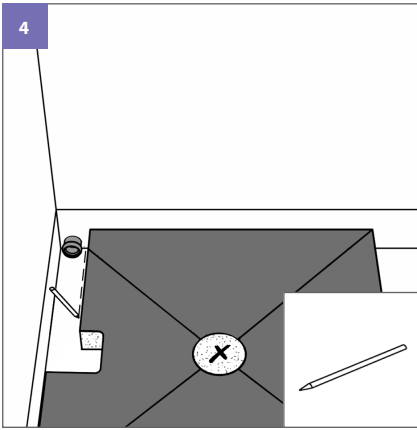

[DE] – ... oder nahezu vollflächig
 [EN] – ... or over the entire substrate
 [FR] – ... ou sur toute la surface du support
 [NL] – ... of over het volledig oppervlak

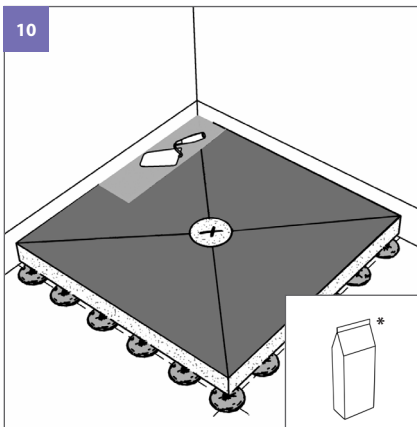
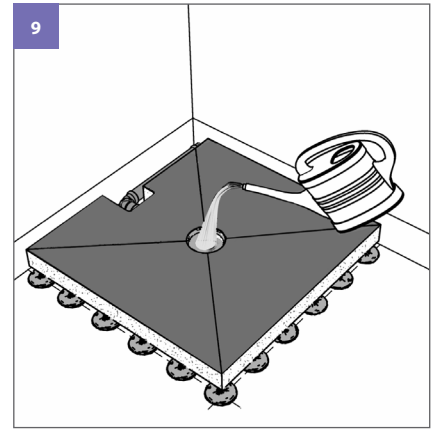
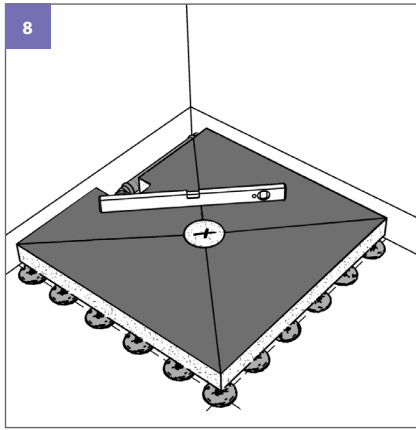
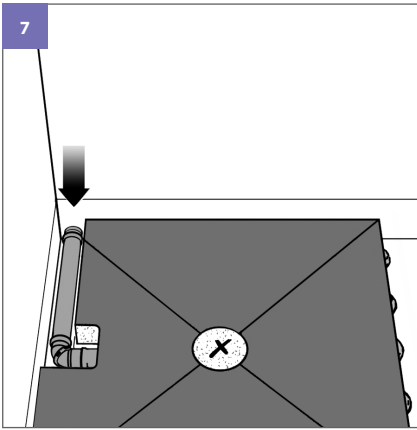

→ 08 1

* [DE] – Fliesenkleber C2 [EN] – Tile adhesive C2
 [FR] – Colle à carrelage C2 [NL] – Tegellijm C2

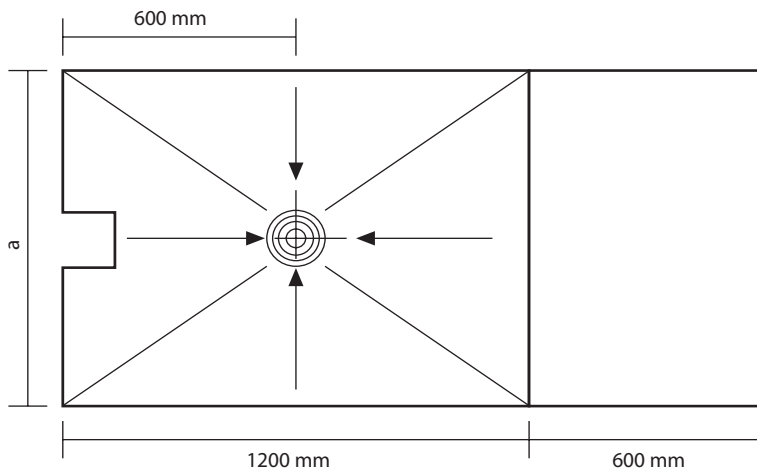

1800/**800**: a = 800 mm

1800/**900**: a = 900 mm

1800/**1000**: a = 1000 mm

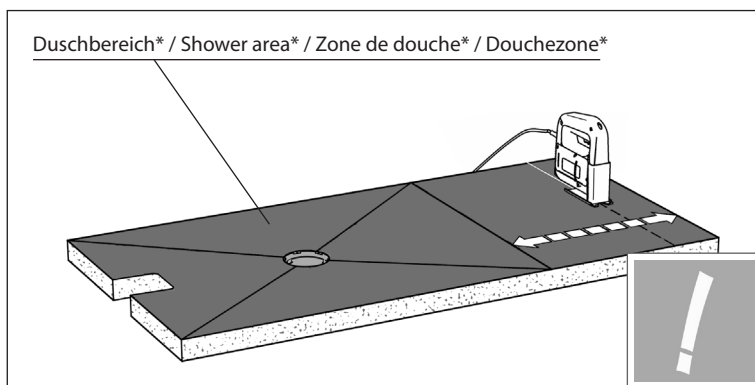

* [DE] – Die Armaturen ... sind im Duschbereich anzuordnen.

[EN] – The fittings ... are to be located in the shower area.

[FR] – Les alimentations et robinetteries ... doivent être aménagés dans la zone de douche.

[NL] – De badmonturen ... dienen in de douchezon aangebracht te worden.

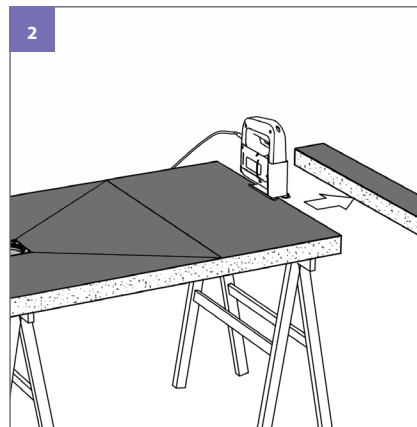
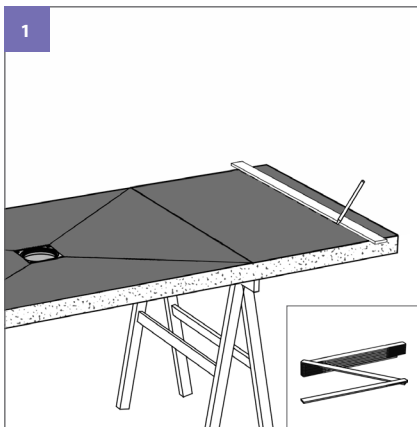

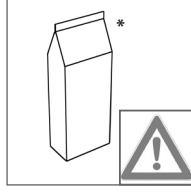
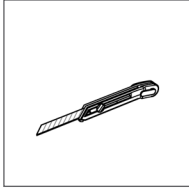
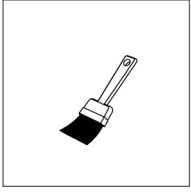

HINWEIS · PLEASE NOTE · REMARQUE · LET OP:

* JACKOBOARD® Abdichtungsset 2-k

[DE] – Schutzhandschuhe/-kleidung, Augen- u. Gesichtsschutz tragen

[EN] – Wear protective gloves/clothing, eye and face protection

[FR] – Porter des gants/vêtements de protection, équipement de protection des yeux/du visage

[NL] – Beschermende handschoenen/kleding, oog- en gelaatsbescherming dragen in deze

handleiding niet behandeld.

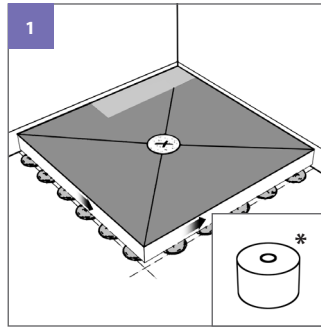
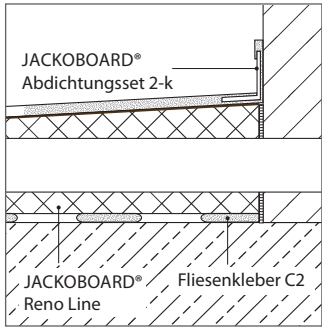

* [DE] – Randdämmstreifen
[EN] – Edge insulation strip
[FR] – Bandes périphériques
[NL] – Randisolatiestrook

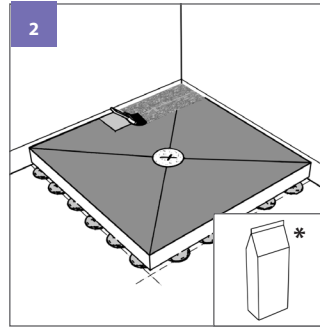

* [DE] – JACKOBOARD® Abdichtungsset 2-k
[EN] – JACKOBOARD® Sealing set 2-k
[FR] – JACKOBOARD® Kit d'étanchéité 2-k
[NL] – JACKOBOARD® Afdichtingsset 2-k

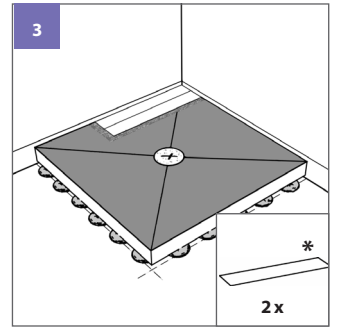

* [DE] – Dichtband
[EN] – sealing tape
[FR] – ruban d'étanchéité
[NL] – afdichtingstape

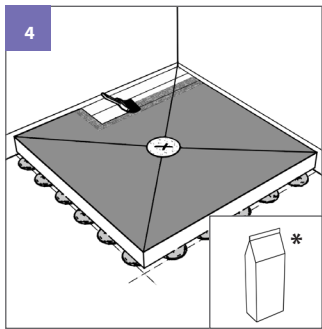

* [DE] – JACKOBOARD® Abdichtungsset 2-k
[EN] – JACKOBOARD® Sealing set 2-k
[FR] – JACKOBOARD® Kit d'étanchéité 2-k
[NL] – JACKOBOARD® Afdichtingsset 2-k

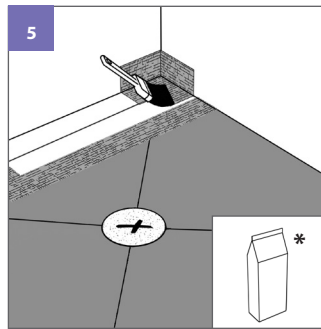

* [DE] – JACKOBOARD® Abdichtungsset 2-k
[EN] – JACKOBOARD® Sealing set 2-k
[FR] – JACKOBOARD® Kit d'étanchéité 2-k
[NL] – JACKOBOARD® Afdichtingsset 2-k

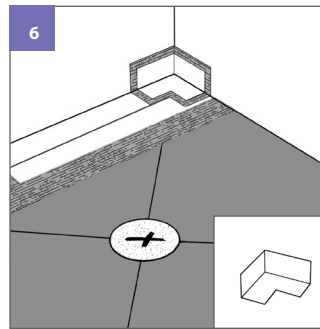

* [DE] – Dichtecke
[EN] – Sealing Corner
[FR] – Coin d'étanchéité
[NL] – Afdichtende hoek

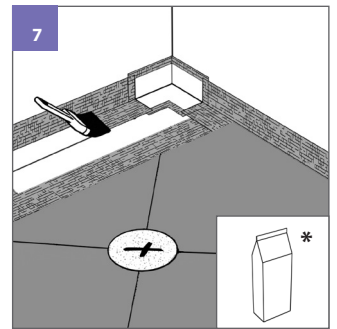

* [DE] – JACKOBOARD® Abdichtungsset 2-k
[EN] – JACKOBOARD® Sealing set 2-k
[FR] – JACKOBOARD® Kit d'étanchéité 2-k
[NL] – JACKOBOARD® Afdichtingsset 2-k

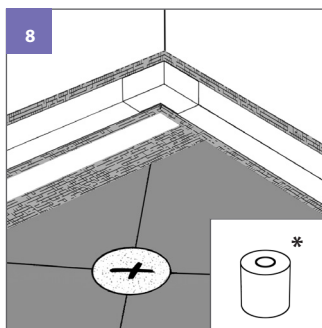

* [DE] – Dichtband
[EN] – sealing tape
[FR] – ruban d'étanchéité
[NL] – afdichtingstape

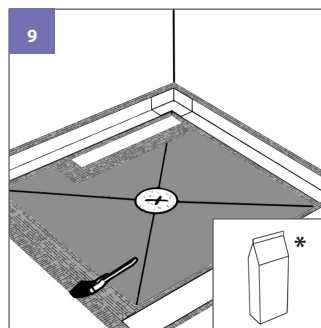

* [DE] – JACKOBOARD® Abdichtungsset 2-k
[EN] – JACKOBOARD® Sealing set 2-k
[FR] – JACKOBOARD® Kit d'étanchéité 2-k
[NL] – JACKOBOARD® Afdichtingsset 2-k

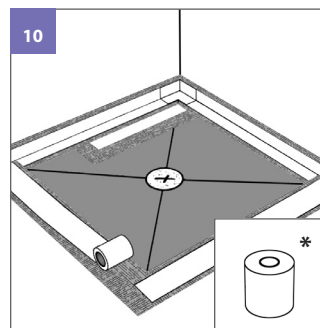

* [DE] – Dichtband
[EN] – sealing tape
[FR] – ruban d'étanchéité
[NL] – afdichtingstape

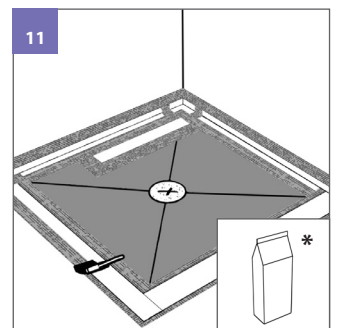

* [DE] – JACKOBOARD® Abdichtungsset 2-k
[EN] – JACKOBOARD® Sealing set 2-k
[FR] – JACKOBOARD® Kit d'étanchéité 2-k
[NL] – JACKOBOARD® Afdichtingsset 2-k

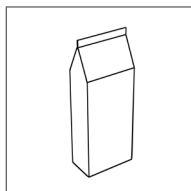
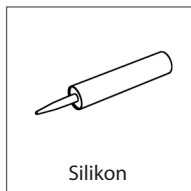
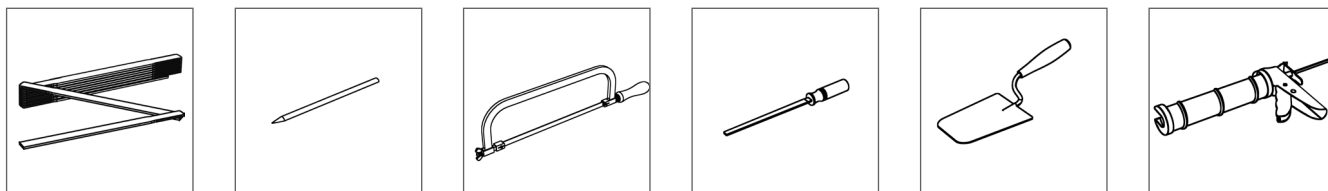

[DE] – Fliesenkleber C2
 [EN] – Tile adhesive C2
 [FR] – Colle à carrelage C2
 [NL] – Tegellijm C2



[DE] – Bitte beachten ...
 vor dem Einpassen der Rost-
 aufnahme den Bauten-
 schutz ('X') entfernen!
 [EN] – Please observe ...
 remove protective cover ('X')
 before fitting the grate!

[FR] – Veuillez tenir compte ... retirer le cou-
 vercle de protection ('X') avant intégration du
 support !

[NL] – Let op ... voor het inpassen van het
 rooster de bescherming ('X') ver-
 wijderen!

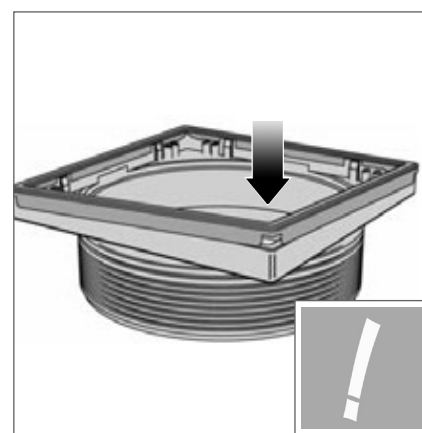
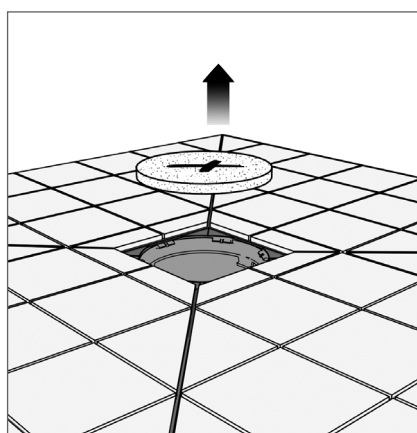

* [DE] – Bautenschutz [EN] – Protective cover
 [FR] – Protection [NL] – Gootbescherming

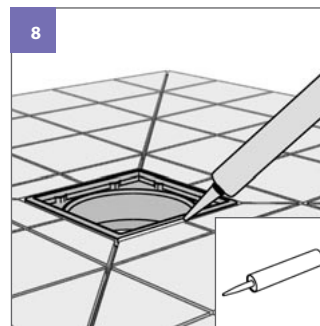
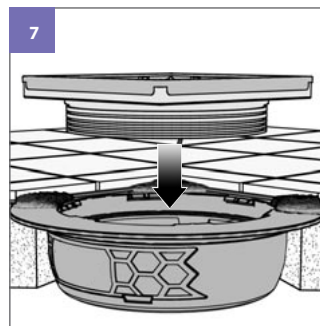
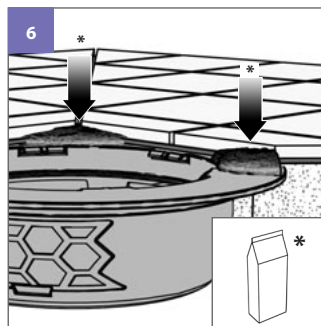
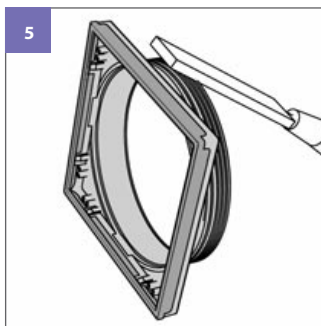
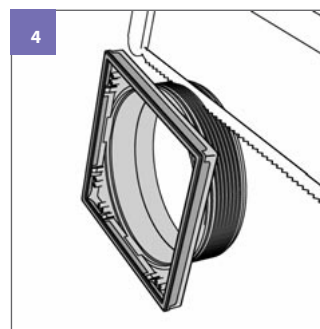
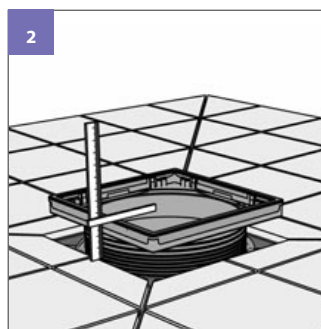
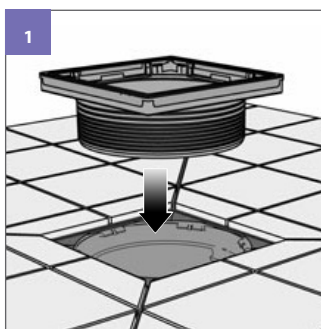

* [DE] – Fliesenkleber C2
 [EN] – Tile adhesive C2
 [FR] – Colle à carrelage C2
 [NL] – Tegellijm C2



[DE] – Bitte beachten ...

Anfließhilfe und Abdecksteg vor der Verfliesung und Verfugung montieren.

[EN] – Please observe ...

Install tiling aid and cover rail before tiling and jointing.

[FR] – Veuillez tenir compte ... Positionner le cadre d'aide à la pose du carrelage et le grille en ligne avant de carreler et jointoyer.

[NL] – Let op ... Tegelhulp en afdekbrug monteren al vorens te betegelen en te voegen.

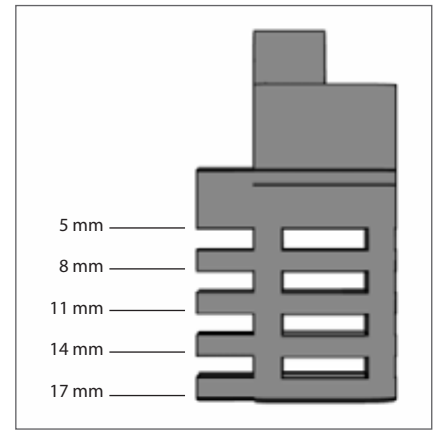
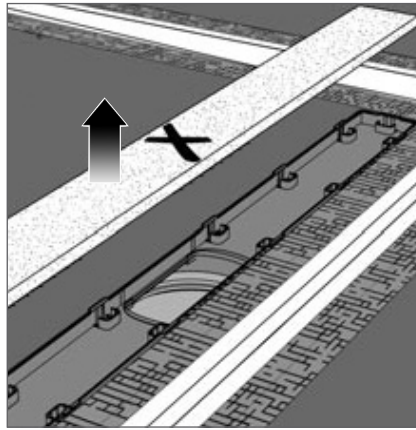

* **[DE] – Bautenschutz** **[EN] – Protective cover**
[FR] – Protection **[NL] – Gootbescherming**

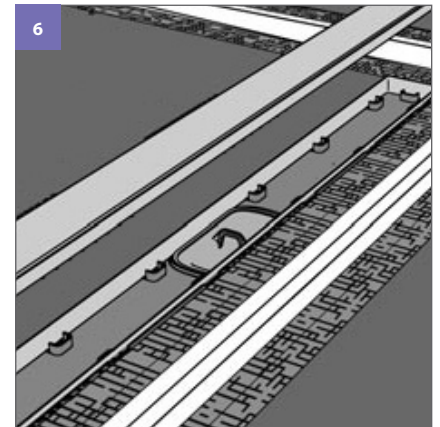
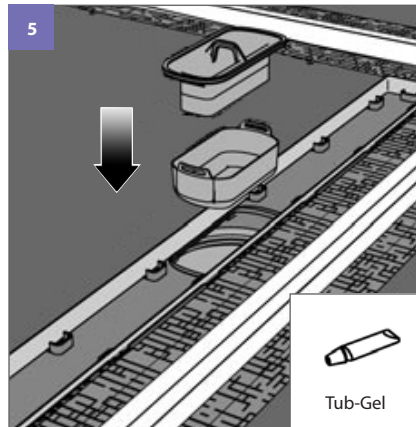
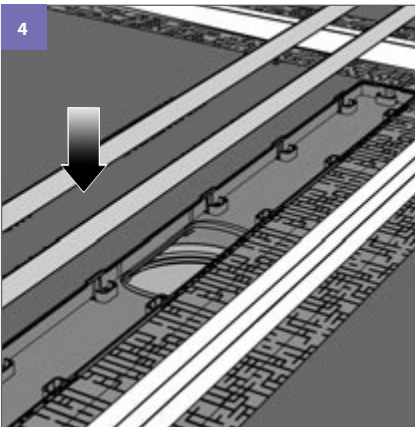
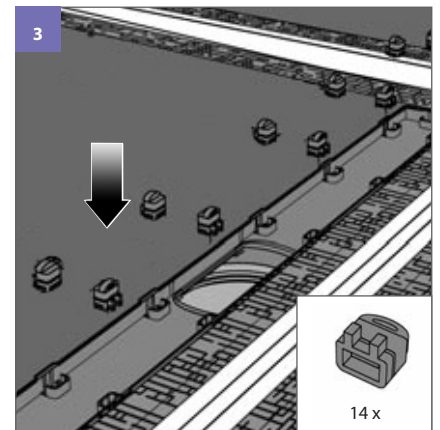
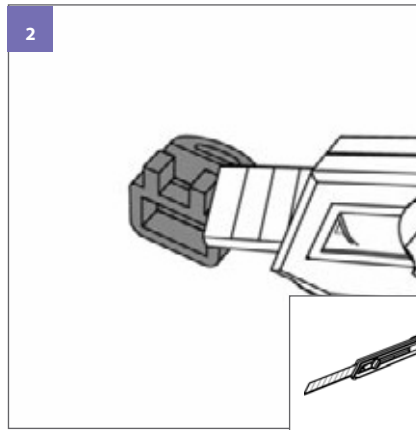
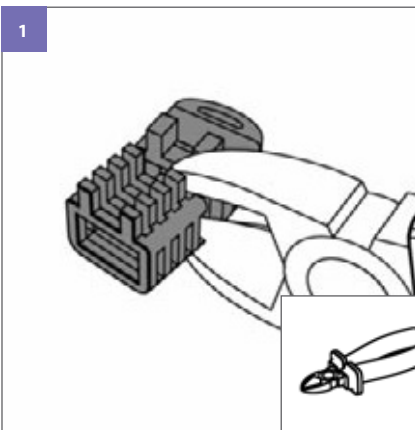

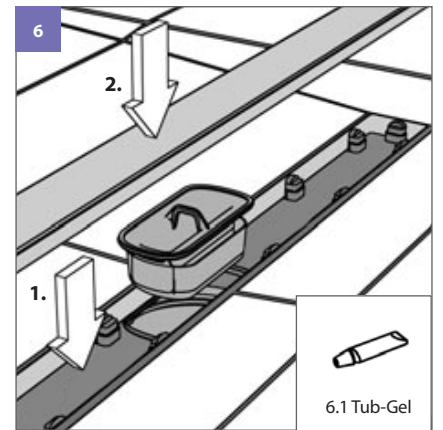
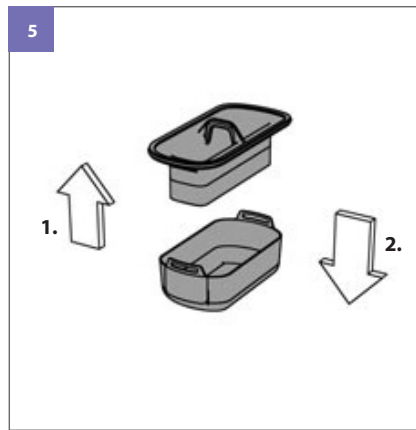
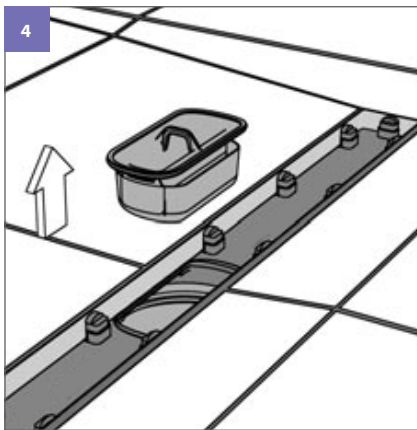
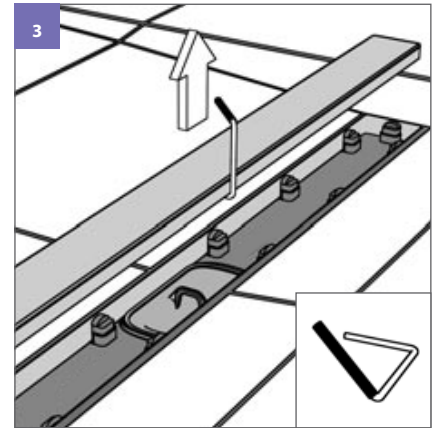
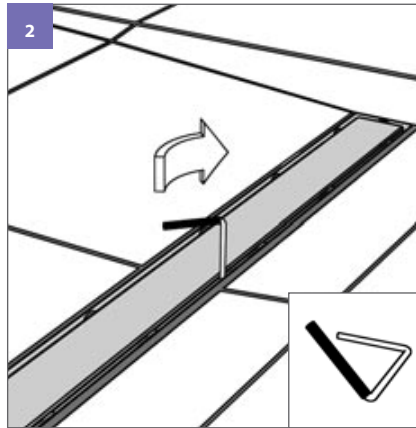
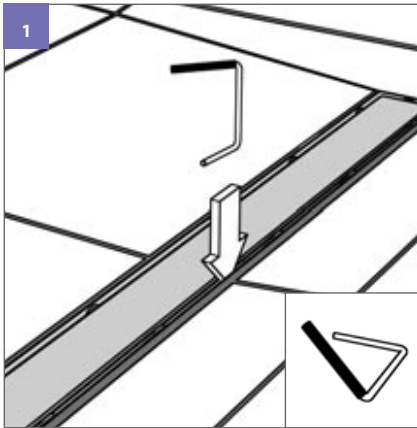

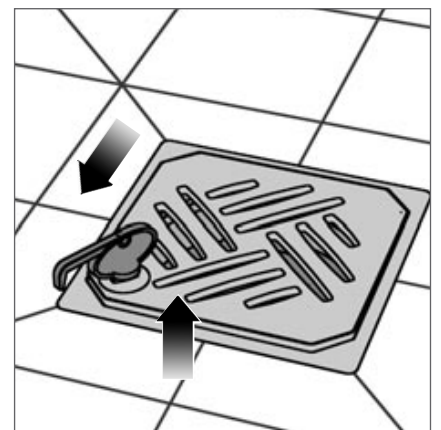
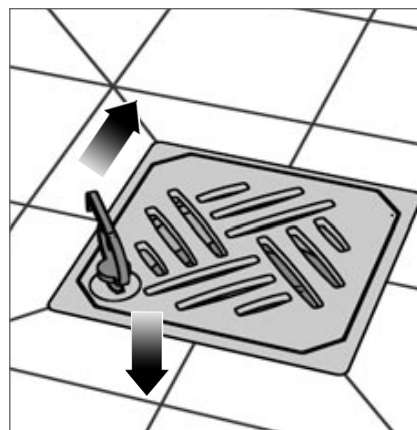
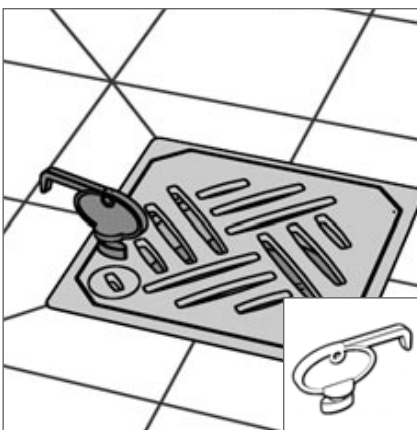
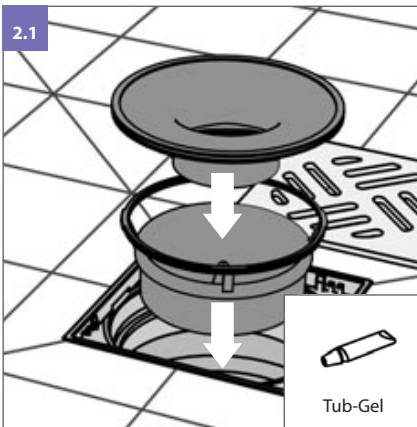
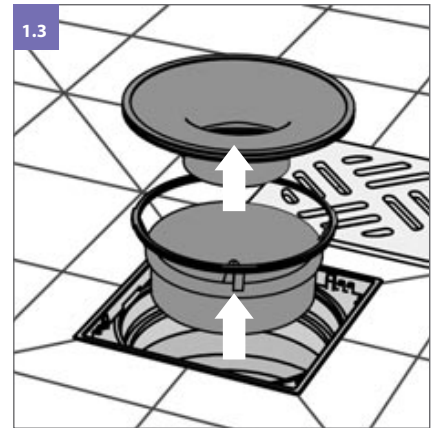
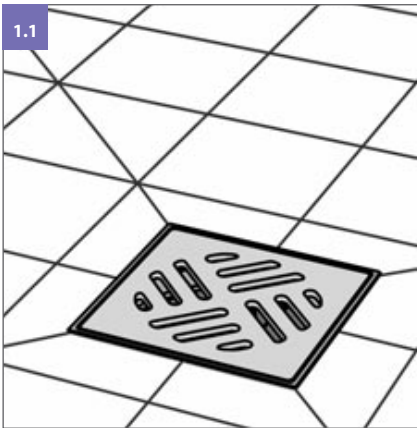

Zur Beachtung

Die Angaben in dieser Druckschrift basieren auf unseren derzeitigen Kenntnissen und Erfahrungen. Sie stellen keine Zusicherung im Rechtssinne dar. Bei der Anwendung sind stets die besonderen Bedingungen des Anwendungsfalles zu berücksichtigen, insbesondere in bauphysikalischer, bautechnischer und baurechtlicher Hinsicht.

JACKODUR® und JACKOBOARD® sind eingetragene Warenzeichen der JACKON Insulation GmbH. Irrtümer und Änderungen vorbehalten.

Please note

The information provided in this leaflet is based on our knowledge and experience to date. It does not constitute a guarantee in any legal sense. When using this product, please always bear in mind the circumstances of the particular intended application, especially with regard to physical, technical and legal construction issues.

JACKODUR® and JACKOBOARD® are registered trademarks of JACKON Insulation GmbH. Errors and omissions excepted; subject to change.

Remarque

Les conseils et indications contenus dans la présente notice de montage sont basés sur notre expérience et l'état actuel de la technique. Ils ne confèrent aucune garantie et ne présentent aucun caractère contractuel. Il est conseillé de procéder à un examen préalable des spécificités du lieu de montage, notamment quant aux particularités et à la physique du bâtiment, ainsi qu'aux réglementations en vigueur, afin d'adapter en conséquence les conseils figurant sur la notice et de s'assurer de la réalisation du montage dans le respect des règles de l'art.

JACKODUR® et JACKOBOARD® sont des marques déposées de la Société JACKON Insulation GmbH. Sous réserve d'erreurs et de modifications.

Opmerking

De gegevens in dit document zijn gebaseerd op onze huidige kennis en ervaring. Ze vormen geen garantie in juridische zin. Bij de toepassing dient altijd rekening te worden gehouden met de bijzondere omstandigheden van het specifieke geval, met name ook in bouwfysisch, bouwtechnisch en bouwrechtelijk opzicht.

JACKODUR® en JACKOBOARD® zijn geregistreerde handelsmerken van JACKON Insulation GmbH. Vergissingen en wijzigingen voorbehouden.

JACKON Insulation GmbH

Carl-Benz-Straße 8
D-33803 Steinhagen

T +49 (0) 5204 9955 - 0
F +49 (0) 5204 9955 - 400

E info@jackodur.com
W www.jackon-insulation.com

